

Alpair 6  
 Alpair 6.2P | 6.2M  
 driver dimensions  
 drawn by dld | 24-june-2011

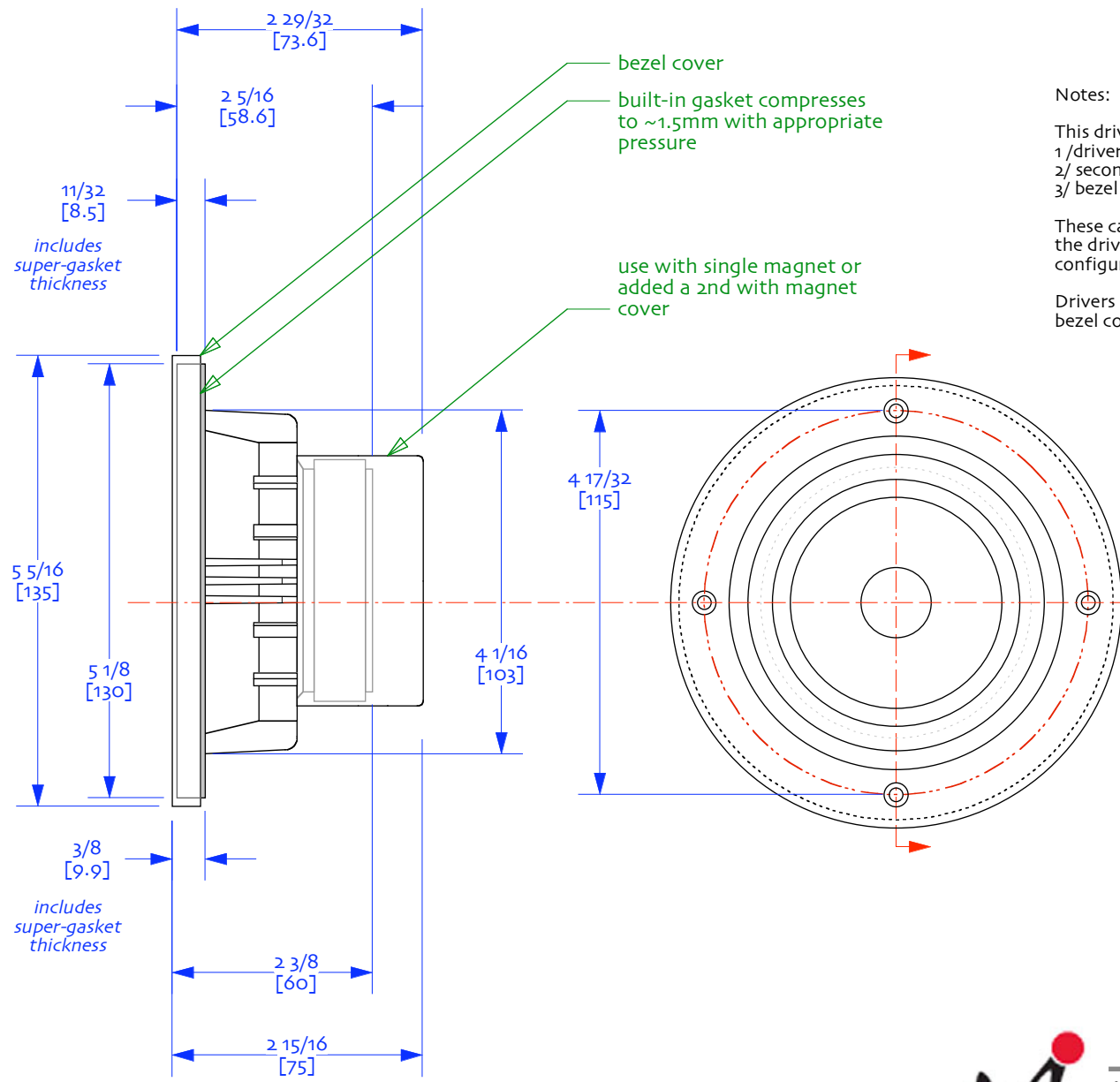

Notes:

This driver comes as 3 separate pieces  
 1/ driver  
 2/ second magnet with magnet cover  
 3/ bezel cover

These can be assembled into 4 configurations of the driver. Individual drawings of each possible configuration are on the next sheet

Drivers come with second magnet attached and bezel cover fitted but not glues/



**Alpair 7.3**  
 All Parts  
 driver dimensions  
 drawn by dld | 23-june-2011

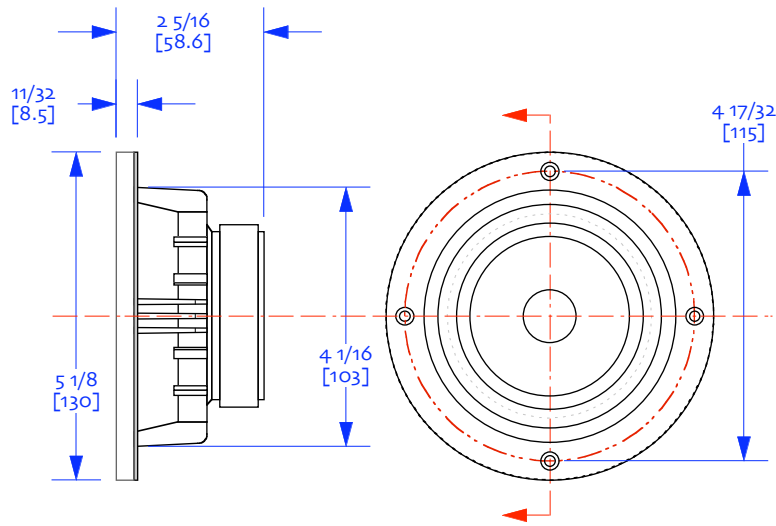

A: 1 magnet / no bezel cover

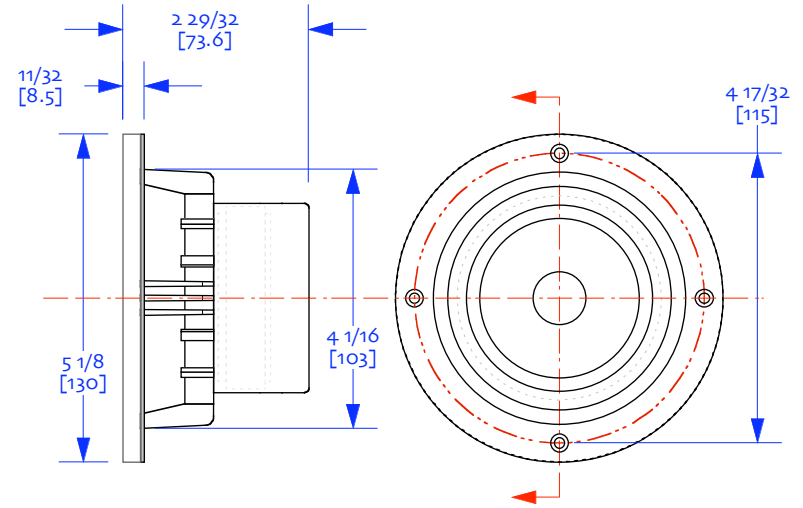

B: 2 magnets / no bezel cover

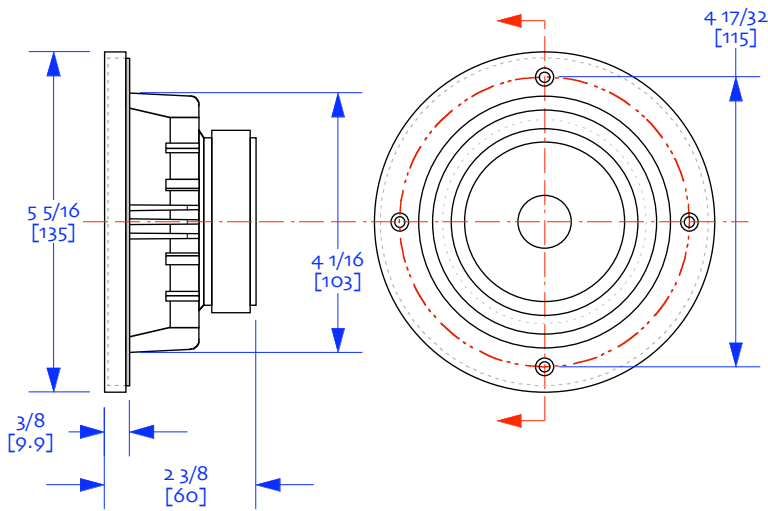

C: 1 magnet / bezel cover

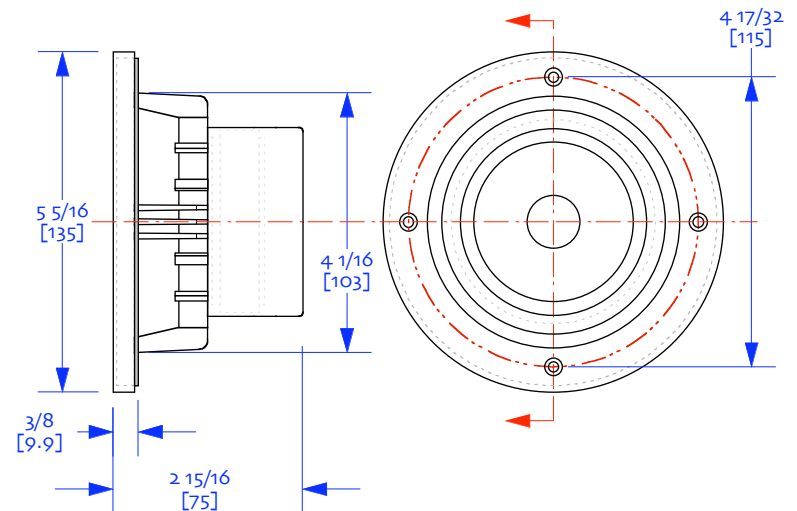

D: 2 magnets / bezel cover



Alpair 7.3  
 4 possibilities  
 driver dimensions  
 drawn by did | 23-june-2011

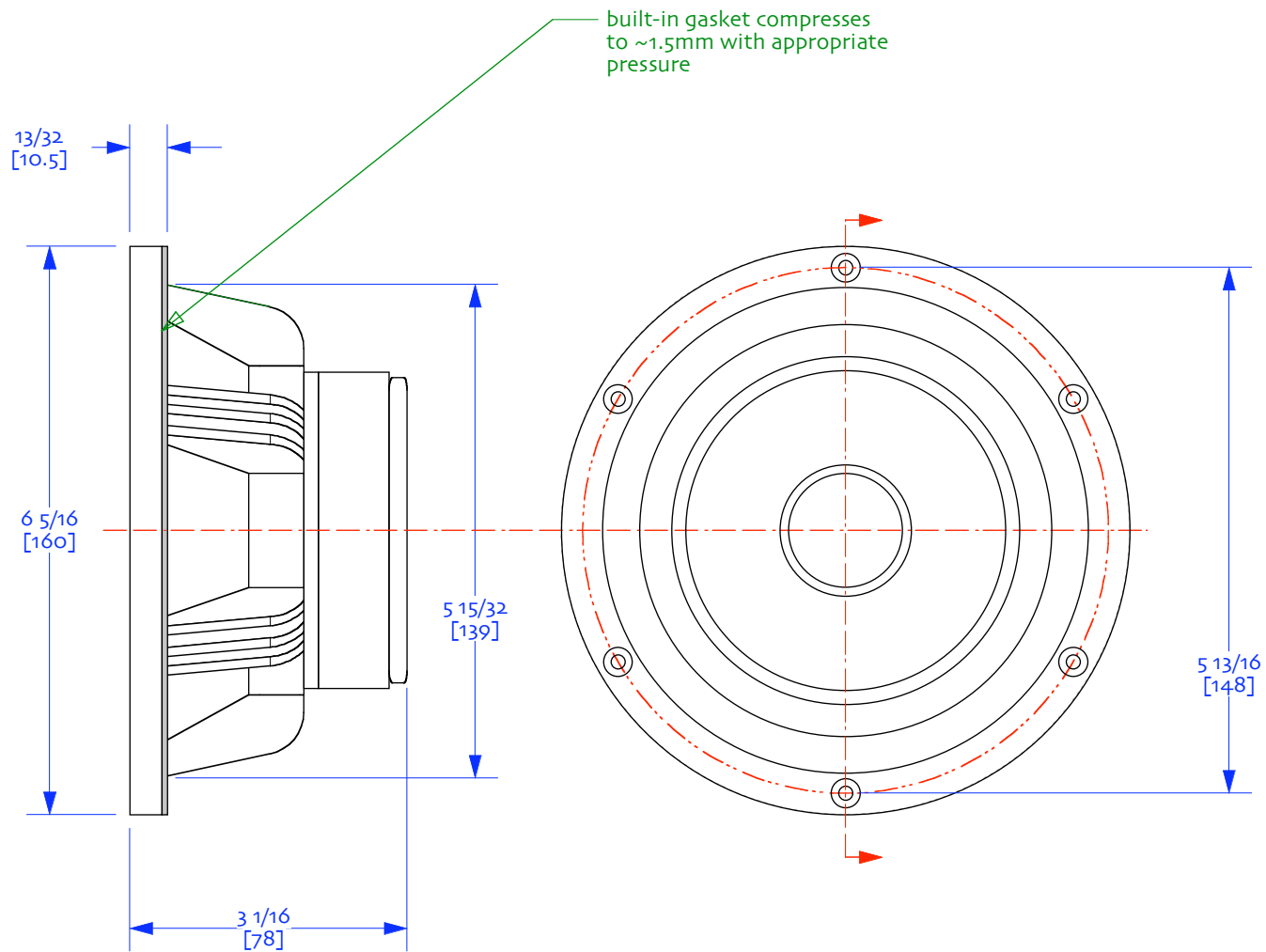

Alpair 10.2  
no bezel cover  
driver dimensions  
drawn by dld | 24-june-2011

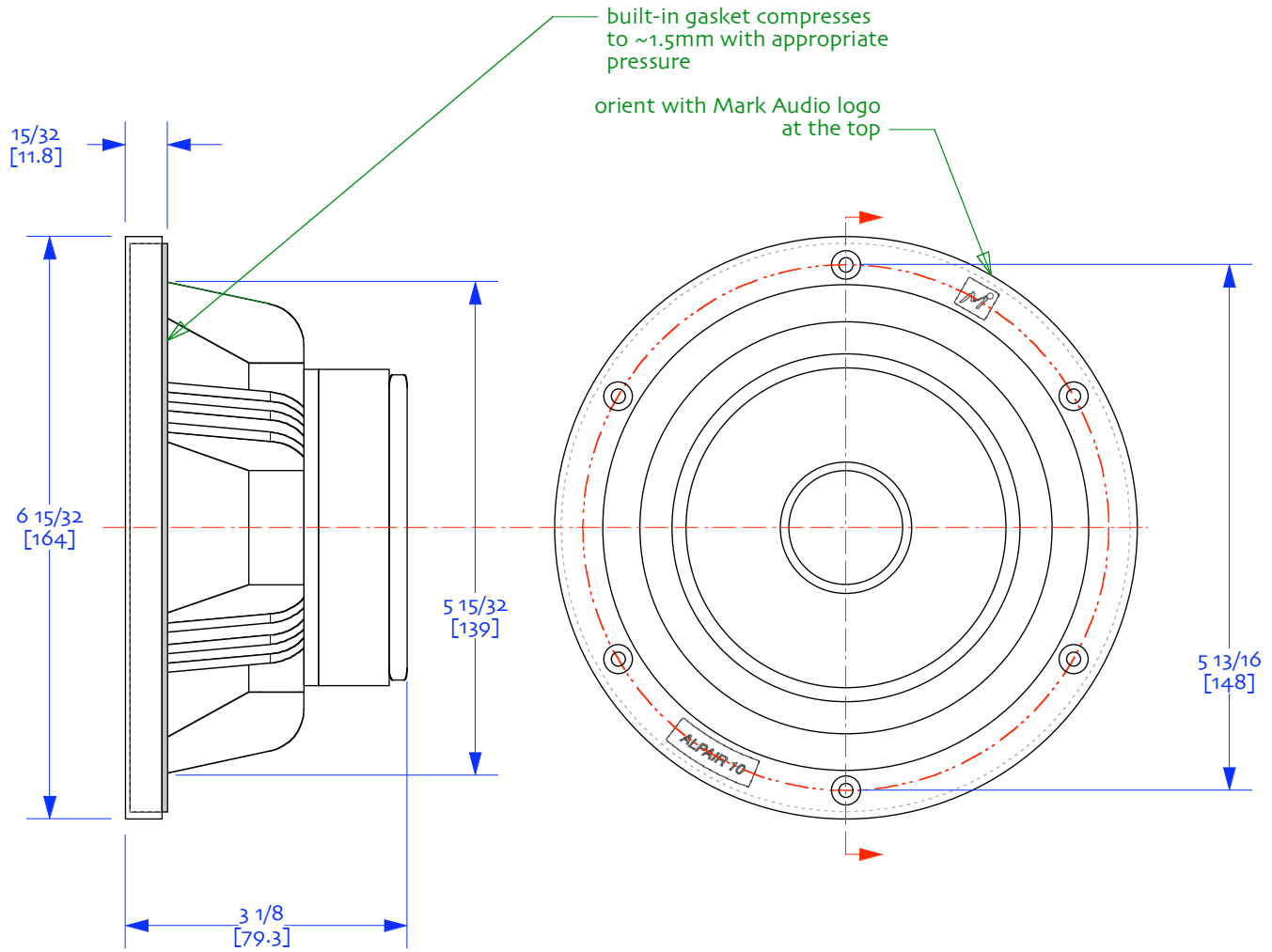

Alpair 10.2  
with bezel cover  
driver dimensions  
drawn by dld | 24-june-2011

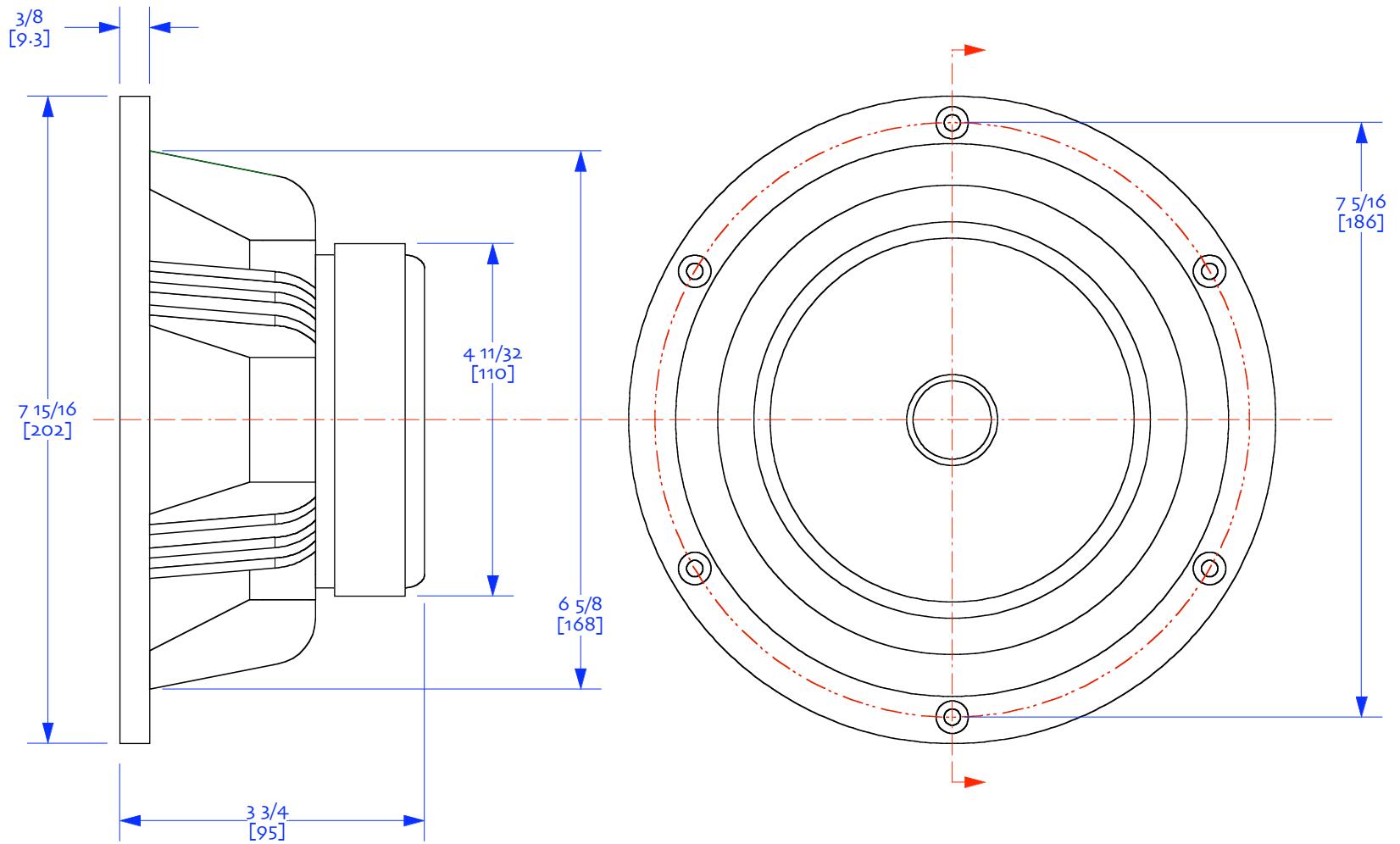

Gasket is 2 mm thick uncompressed, 1,5+mm compressed



Alpair 12  
without bezel cover  
driver dimensions  
drawn by dld | 23-june-2011

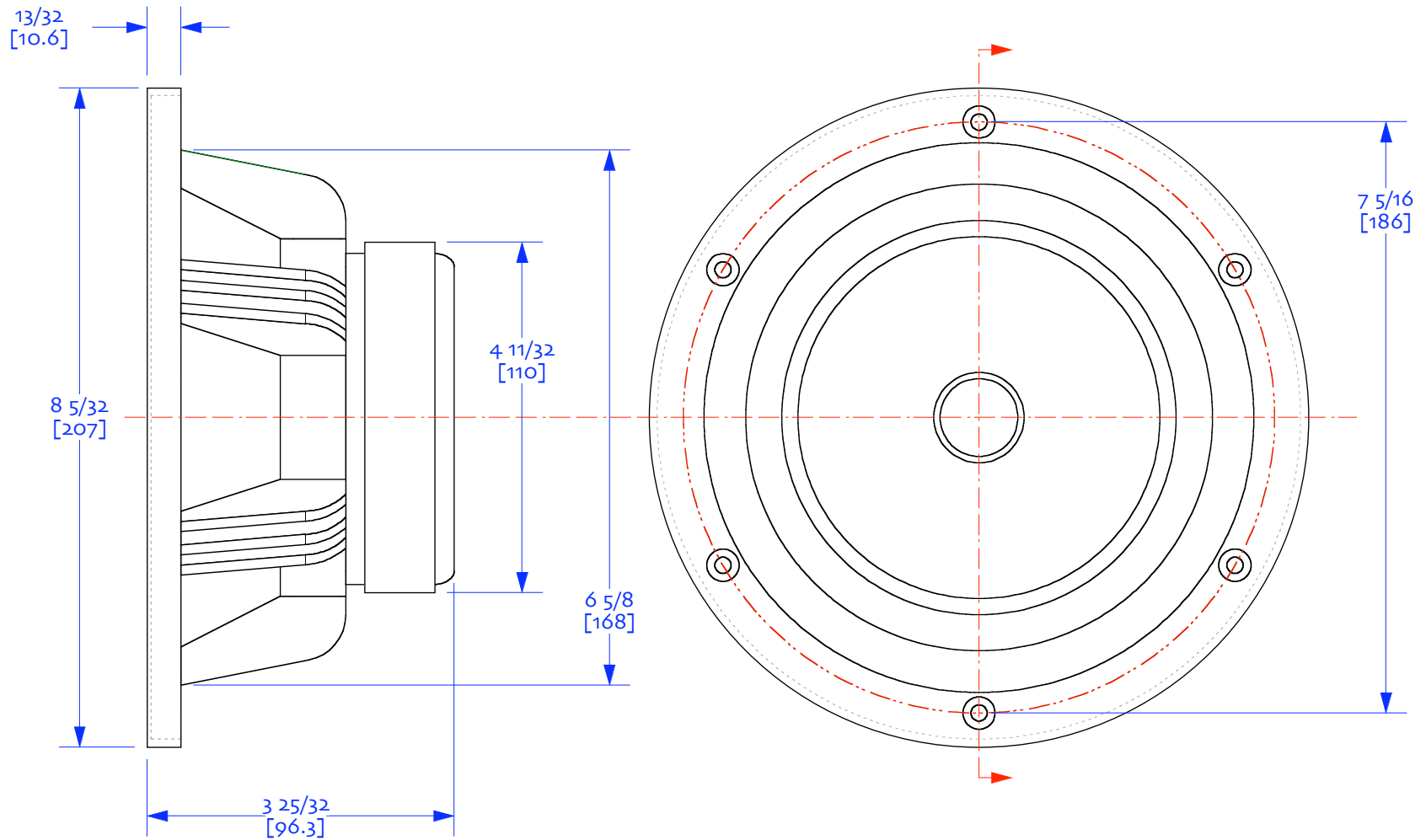

Gasket is 2 mm thick uncompressed, 1.5+mm compressed



Alpair 12  
with bezel cover  
driver dimensions  
drawn by dld | 23-june-2011

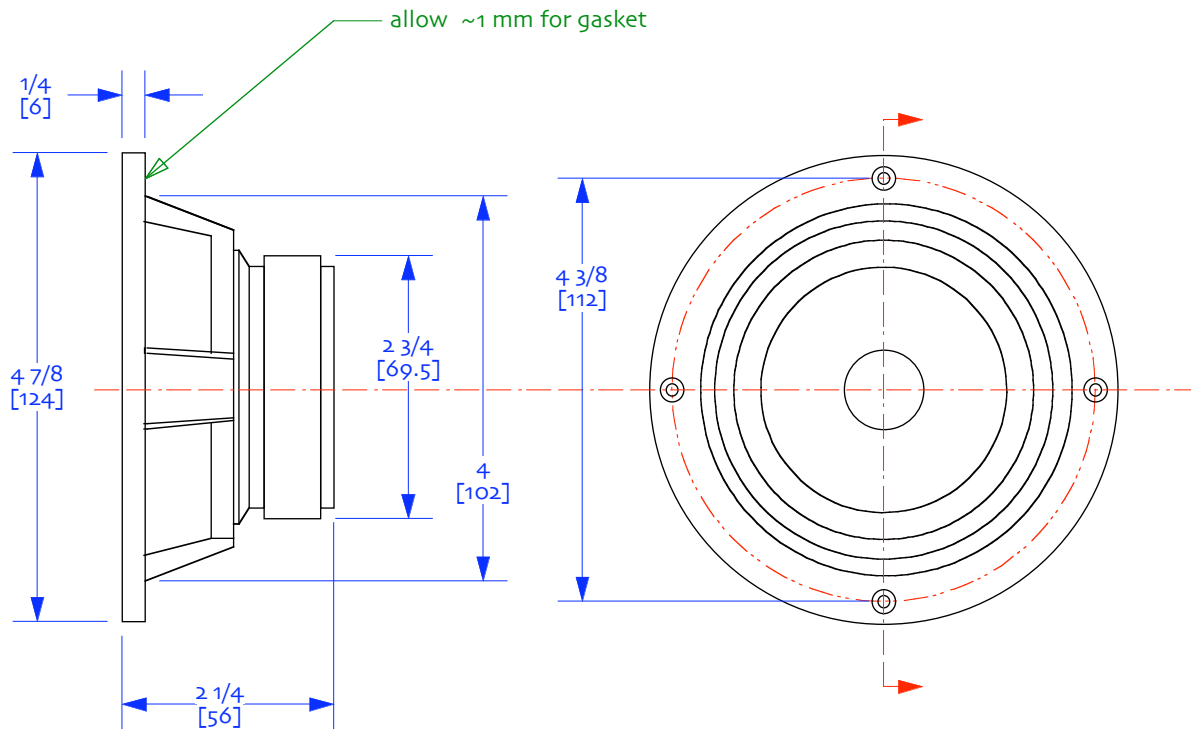

CHR-70.3  
 CHP-70.2  
 CHBW-70  
 driver dimensions  
 drawn by dld | 24june-2011

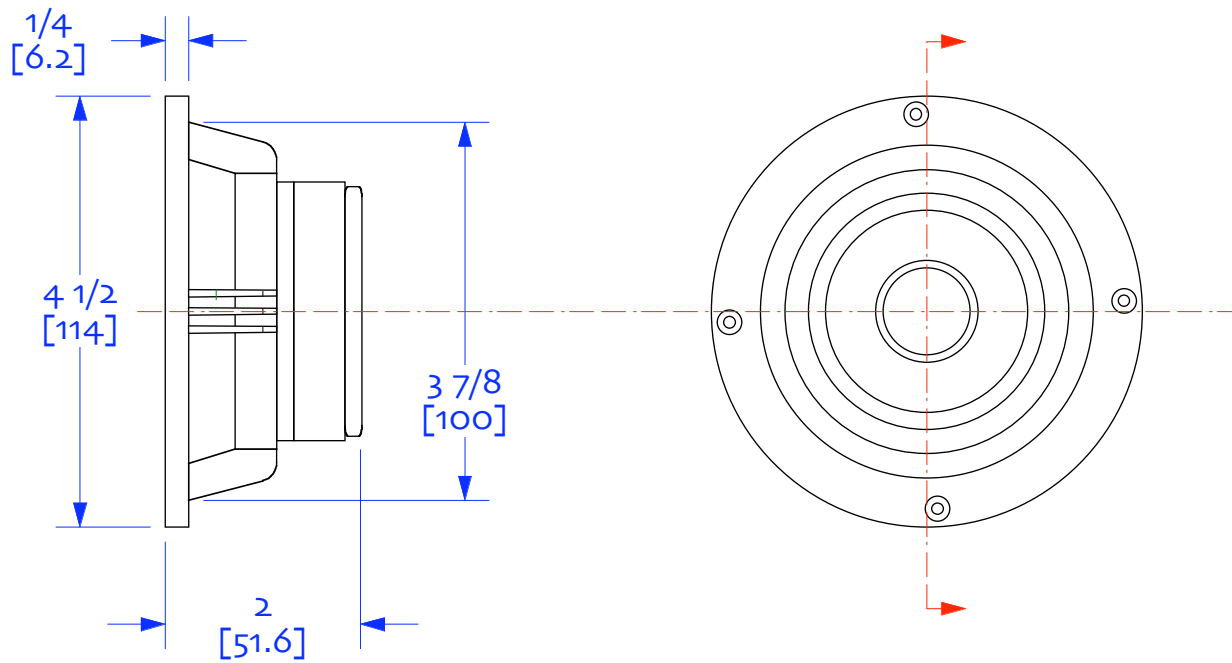

Alpair 5

driver dimensions  
drawn by dld | 23-june-2009

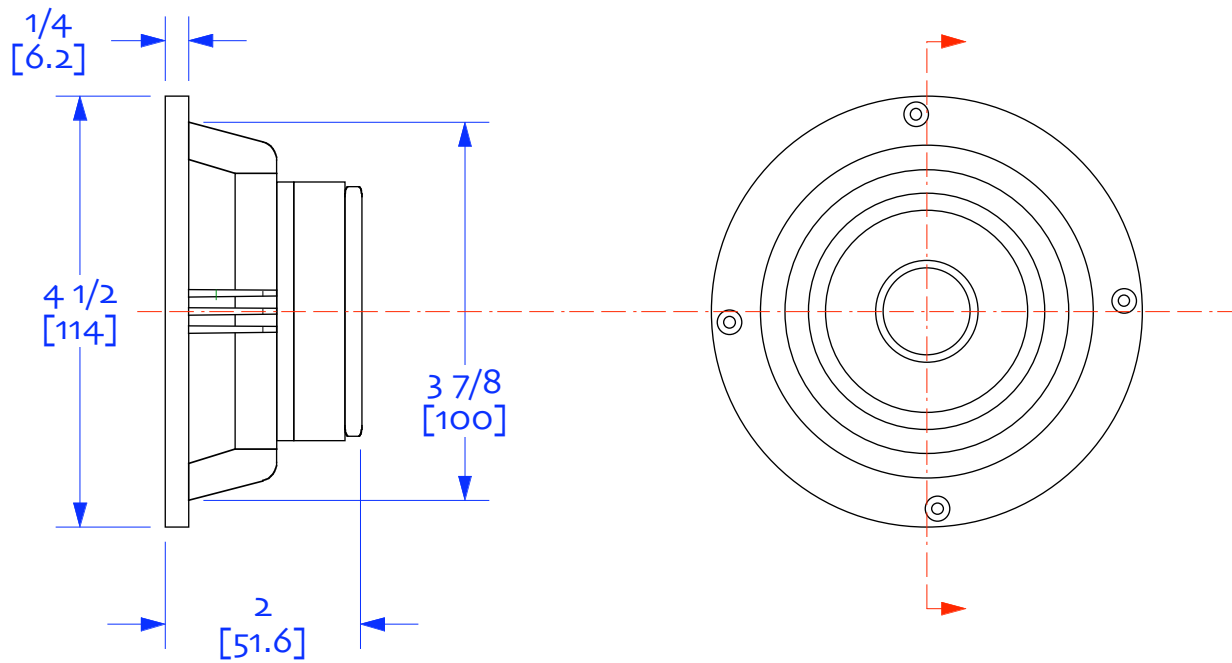

Alpair 6

driver dimensions  
drawn by dld | 23-june-2009

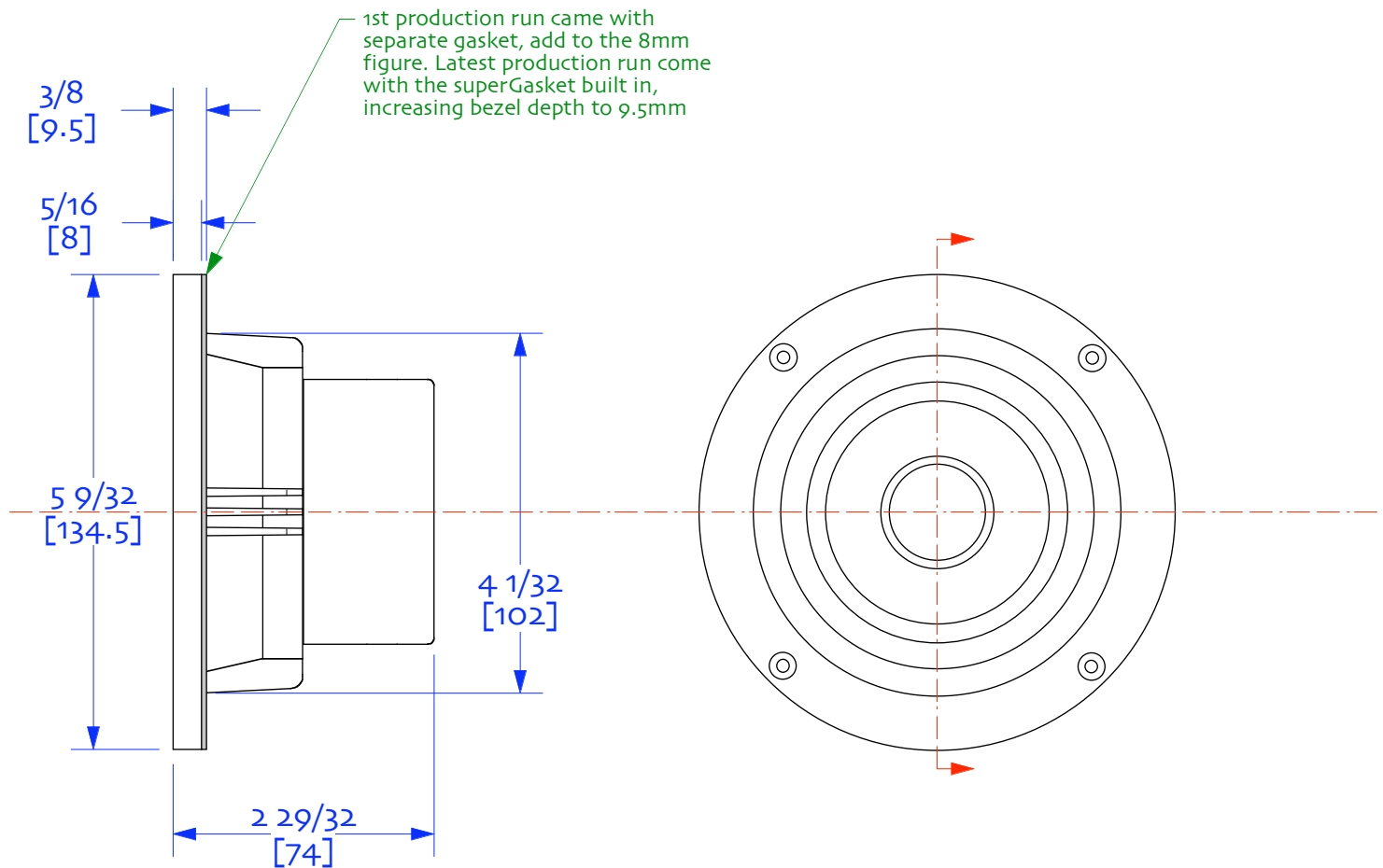

Note:  
o/ actual dimensions taken off a 2nd production run driver



Alpair 7

driver dimensions  
drawn by dld | 21-december-2010

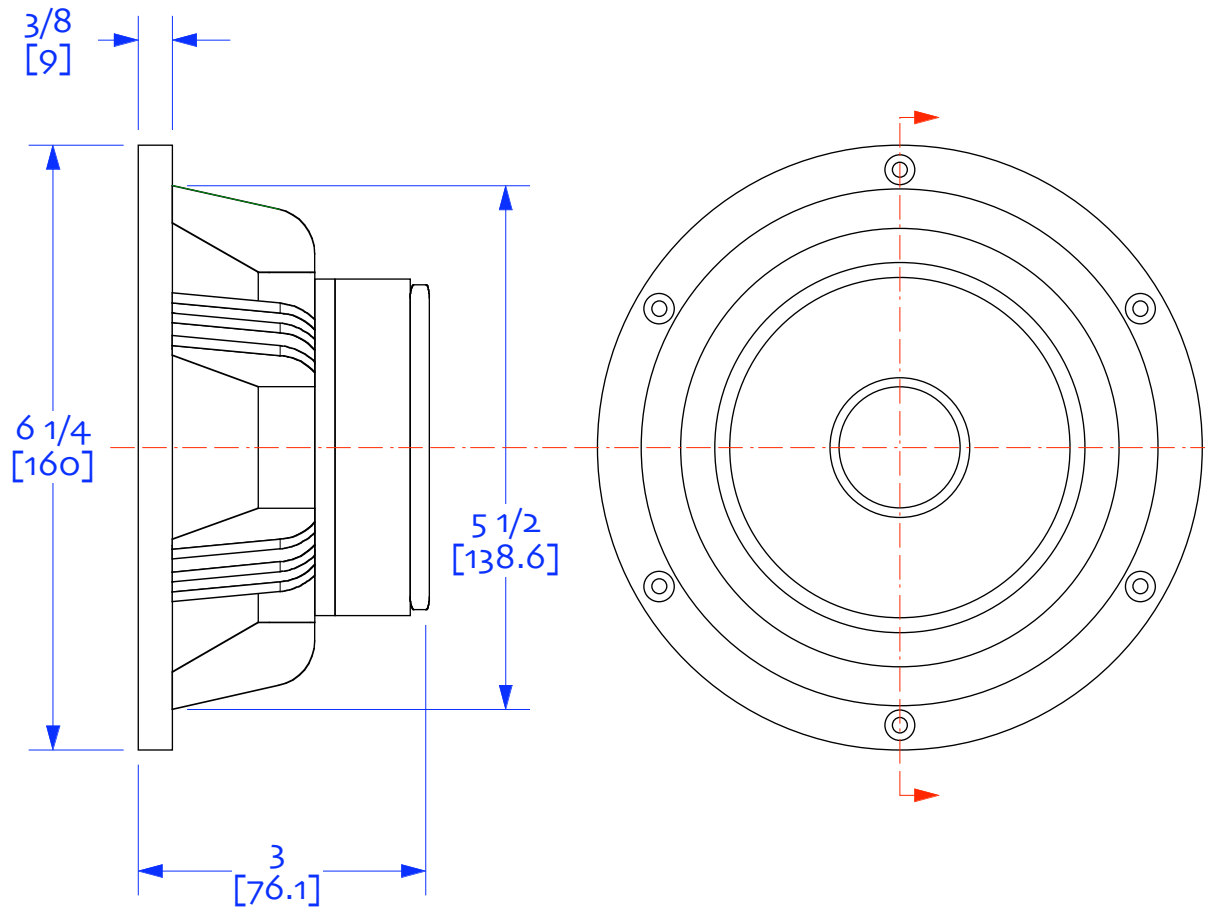

Alpair 10  
driver dimensions  
drawn by dld | 23-june-2009

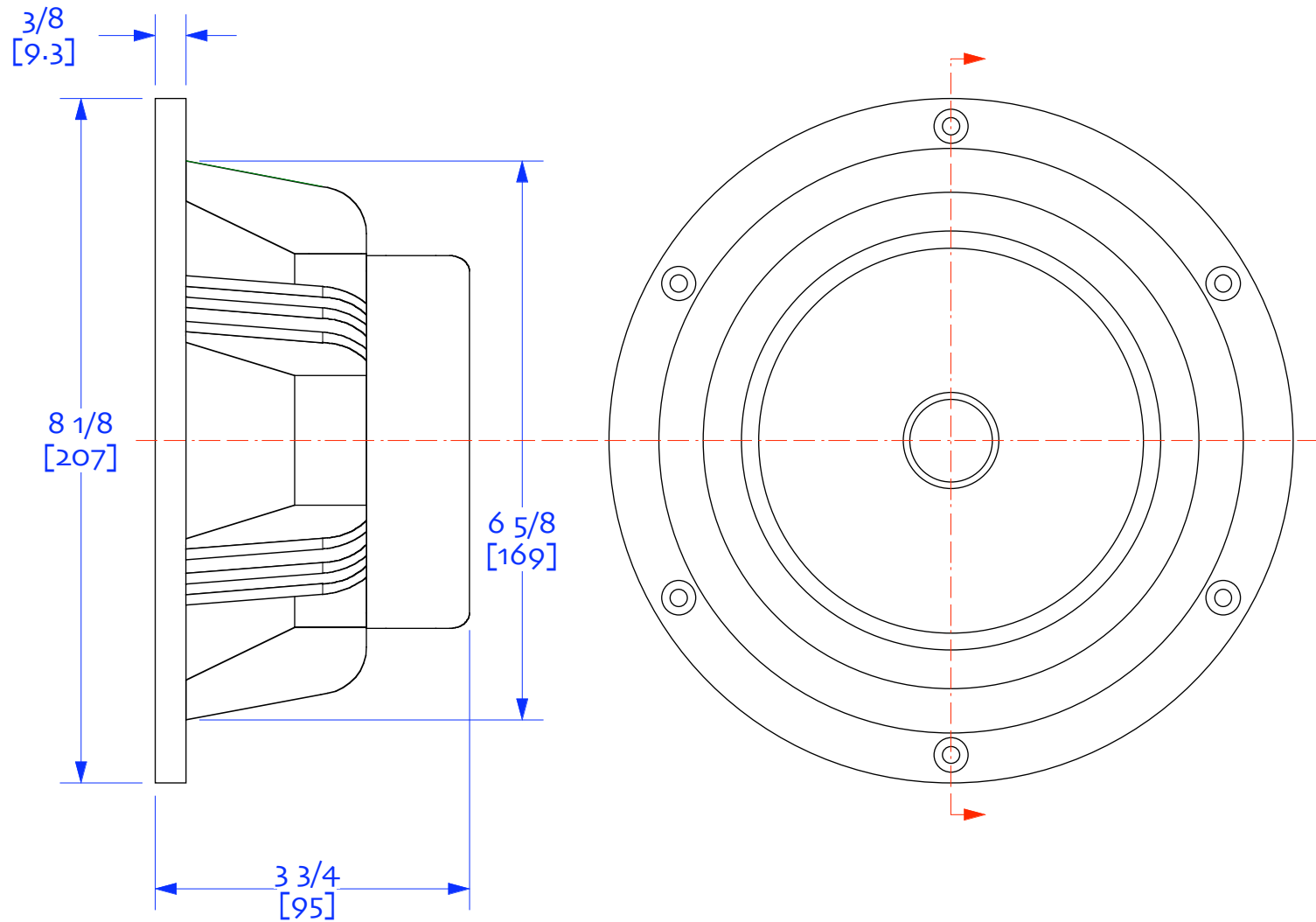

Alpair 12

driver dimensions  
drawn by dld | 20-oct-2009

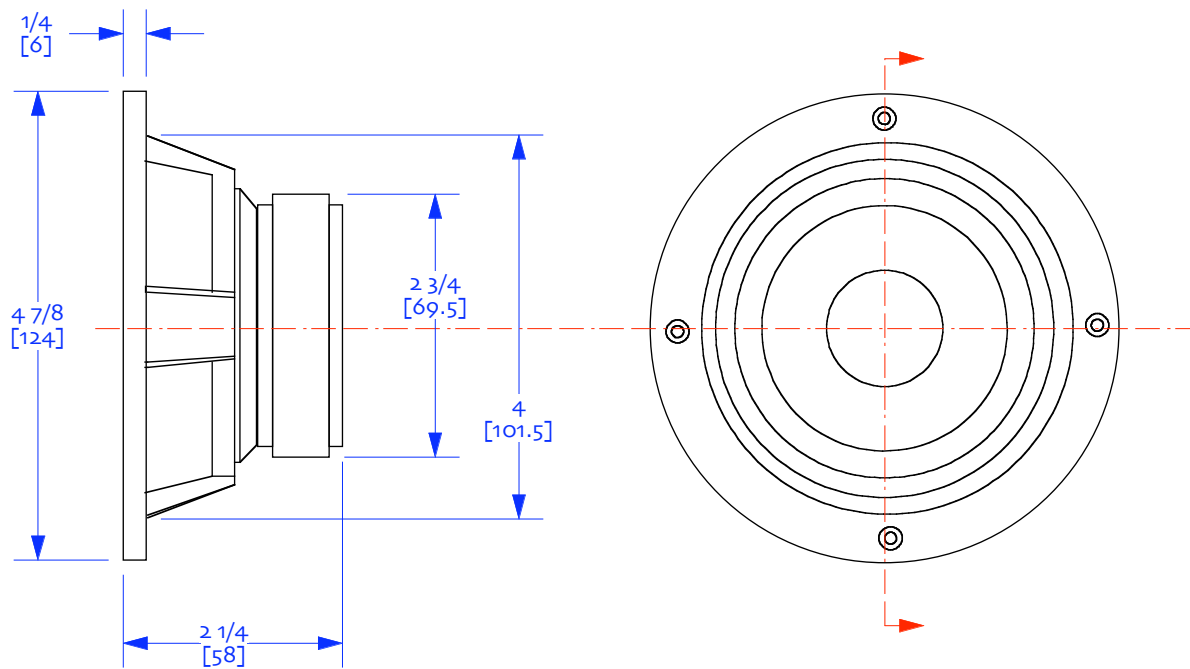

Note that the 2010 CHR-70 comes with a 2mm gasket , which really doesn't compress very much, so it needs to be accounted for when cutting the rebates.



CHR-70

driver dimensions  
drawn by dld | 23-june-2009

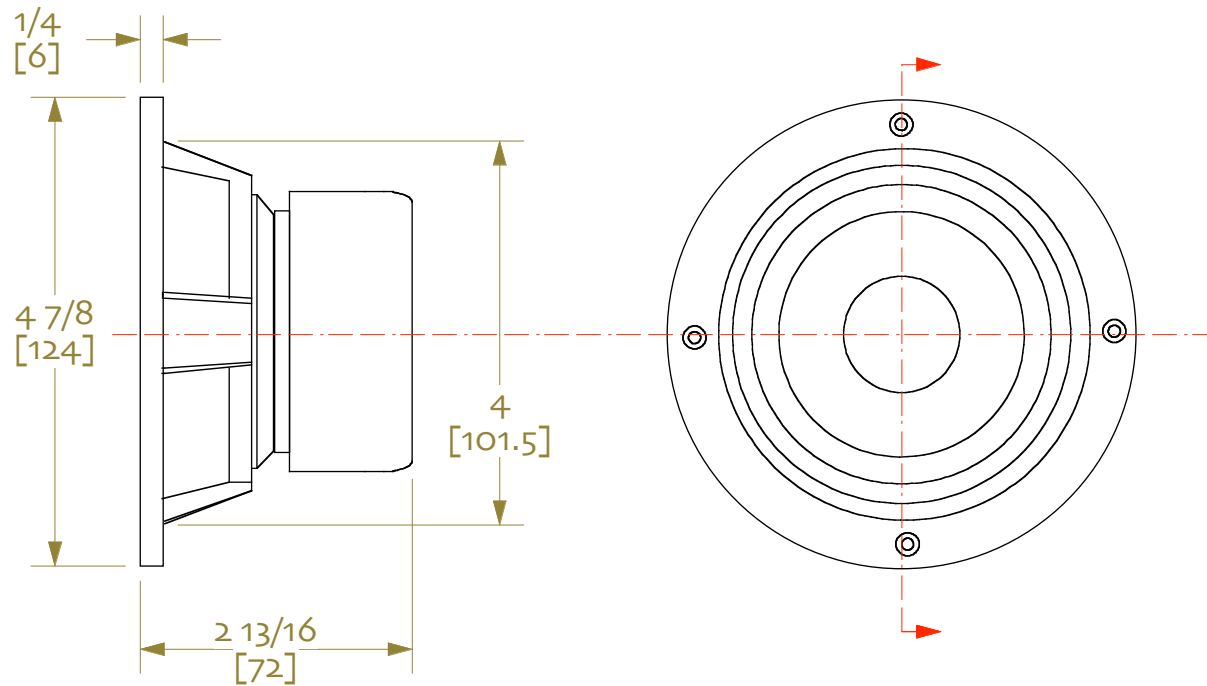

EL70

driver dimensions  
drawn by dld | 23-june-2009

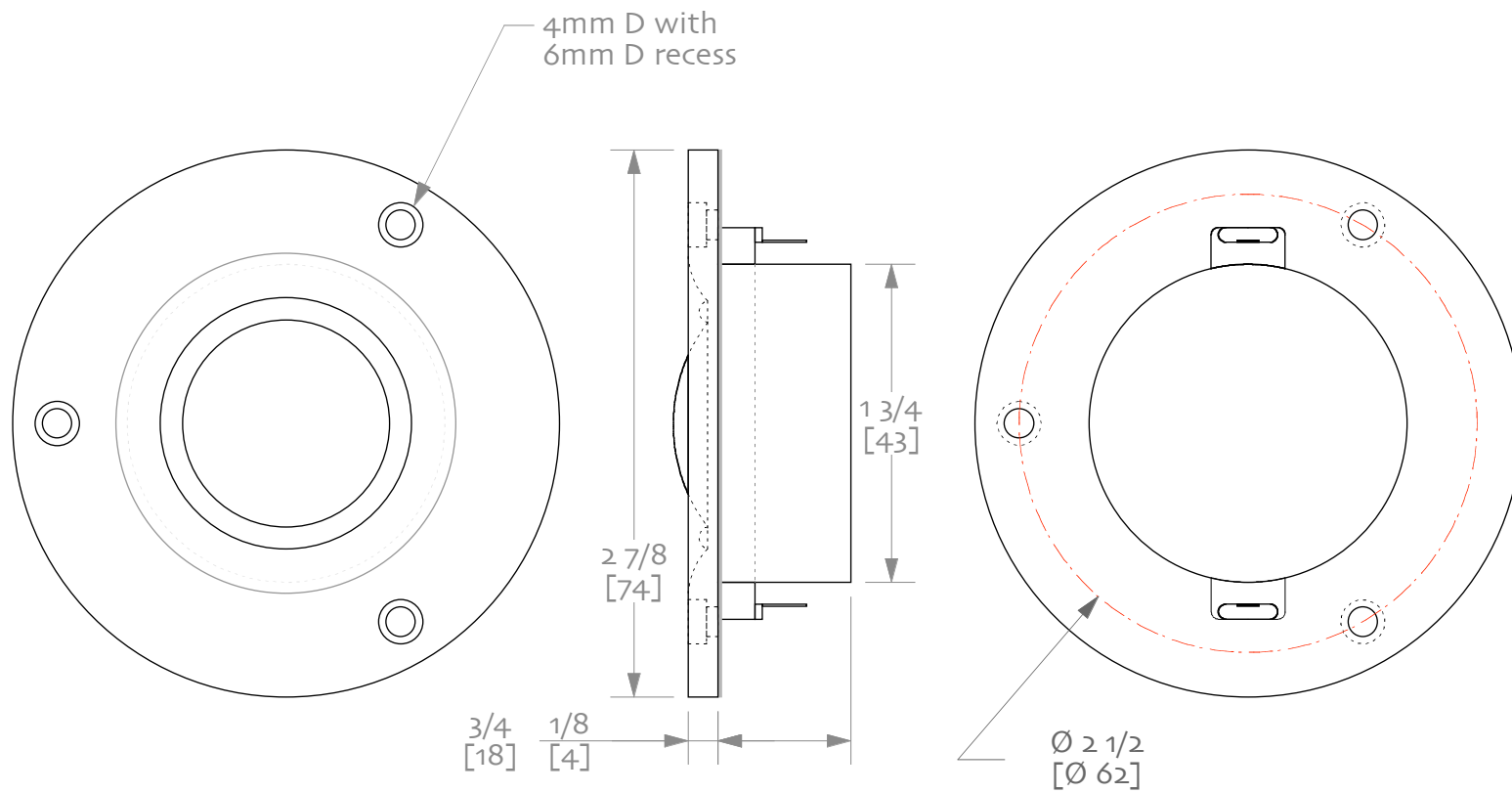

#3 Tweeter

driver dimensions  
drawn by dld | 23-april-2010

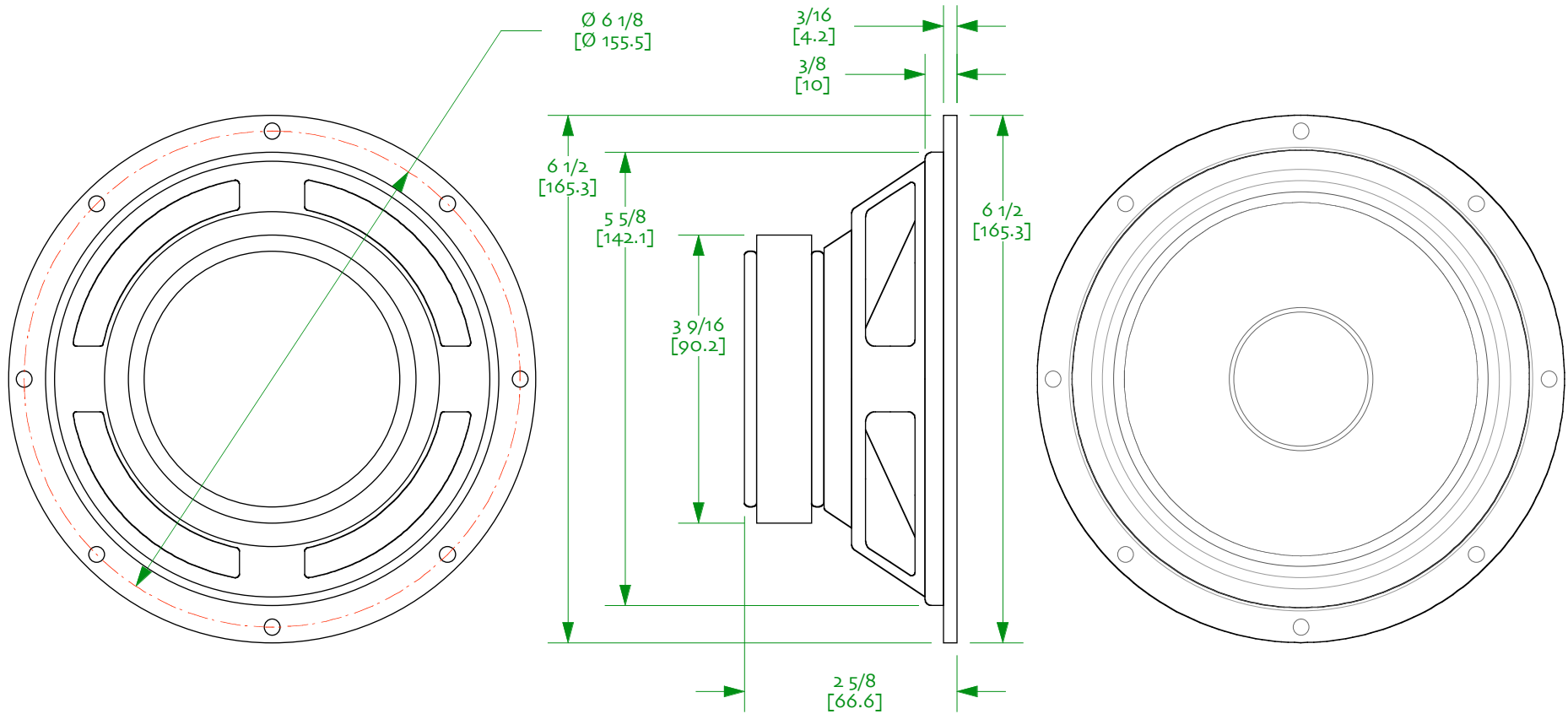

## #6 Woofer

driver dimensions  
drawn by dld | 23-may-2010