

# microTower

(for a pair of Mark Audio CHR-70 or CSS EL70)

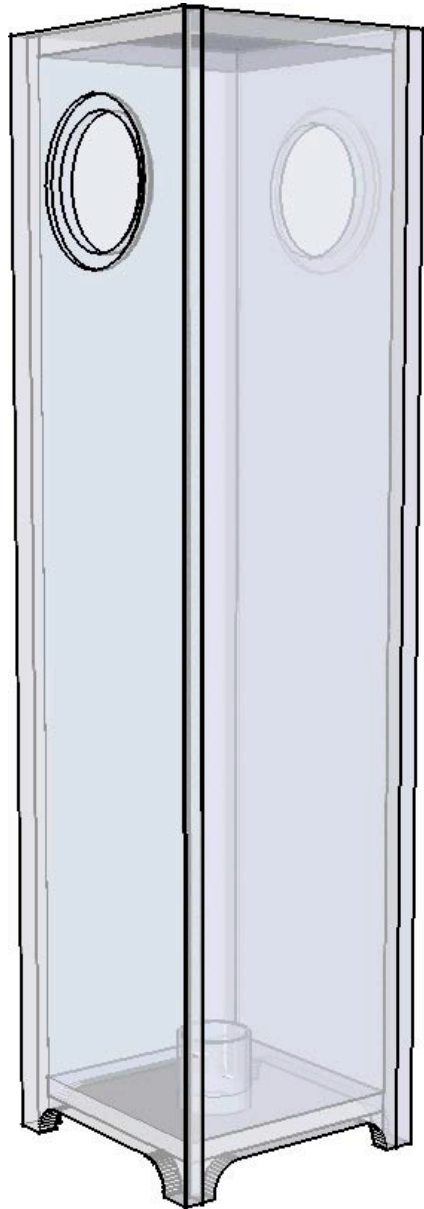

Back in the early '70s while going to University, a group of us hung out at a hifi shop that sold EPI. EPI's were the 2nd store-bought speakers I owned. The miniTower was always my favorite. While discussing a tribute to the miniTower to showcase some drivers we had around, Chris (he used to sell EPIs) suggested that the Mark Audio CHR-70 or CSS EL70 might make a good microTower (probably the most fun EPI and a runaway best seller). The microTower was a push-push end-loaded TL. I consulted Scott Lindgren about the feasibility of squeezing 2 CHR or 2 EL70 into a microTower size ML-TL. Ours ended up a bit taller, but is otherwise faithful. Bass should extend to the mid-40s.



My brain didn't stop at the microTower though. Scott and I had already discussed a Castle Howard inspired box (1 driver forward, 1 facing up). That led to a 45° up & to the rear facing baffle inspired by the BD Pipe.

It is common to double the cross-section and double the ports, to turn a monopole into a bipole, we can do that here and get an omni-pole. Going the other way you could also "saw" the box in half, halve the port and end up with a small monopole floorstander or wall-mount.

Something that we did when we were playing with these was to stack them – this later became accepted practice with the Stacked Advents. Flip one set upside down on another. Imagine a quad of stacked chubbyTowers in your party room... 32 CHR-70s or EL70 chugging away :^D

This document presents the basic speaker, and then ideas to inspire alterations to it to best fit your needs & whims. Have a look at the original microTowers for even more ideas.

<<http://www.humanspeakers.com/e/epi-mt-group.htm>>

David Dlugos

15-september-2009  
© 2009 planet\_10 enterprises limited

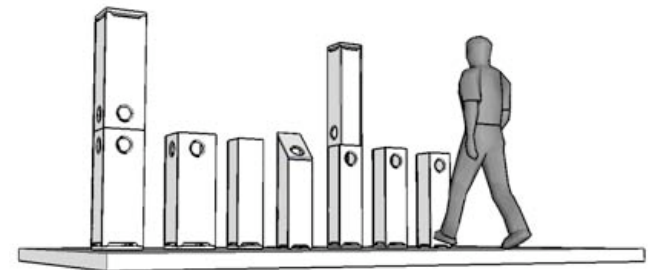
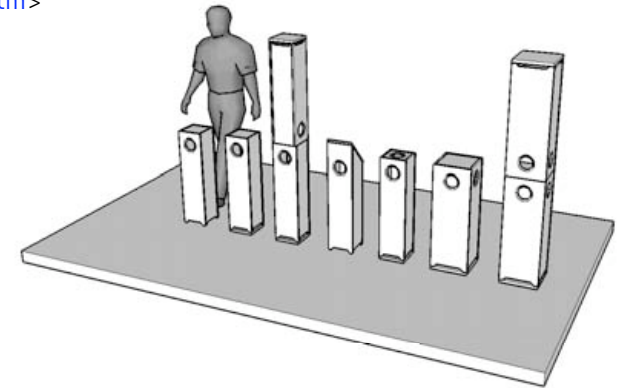

# microTower Series

pictures of 2 proof of concept builds

13-august-09

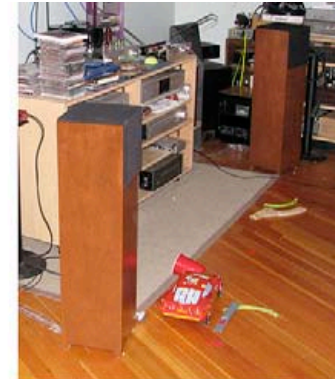

Notes:  
 0/ All panels 15mm (5/8") thick  
 1/ brace shape is only suggestive -- prime purpose is to brace speaker, it needs to be about 35-40% holes. (ie if you have to mount a terminal cup in the middle, you'll want to make sure the brace allows clearance)  
 2/ Line top, back & 1 sidewall with 1" acoustic fiberglass, then tune to taste  
 3/ drivers can be mounted on adjacent sides as well as push-push

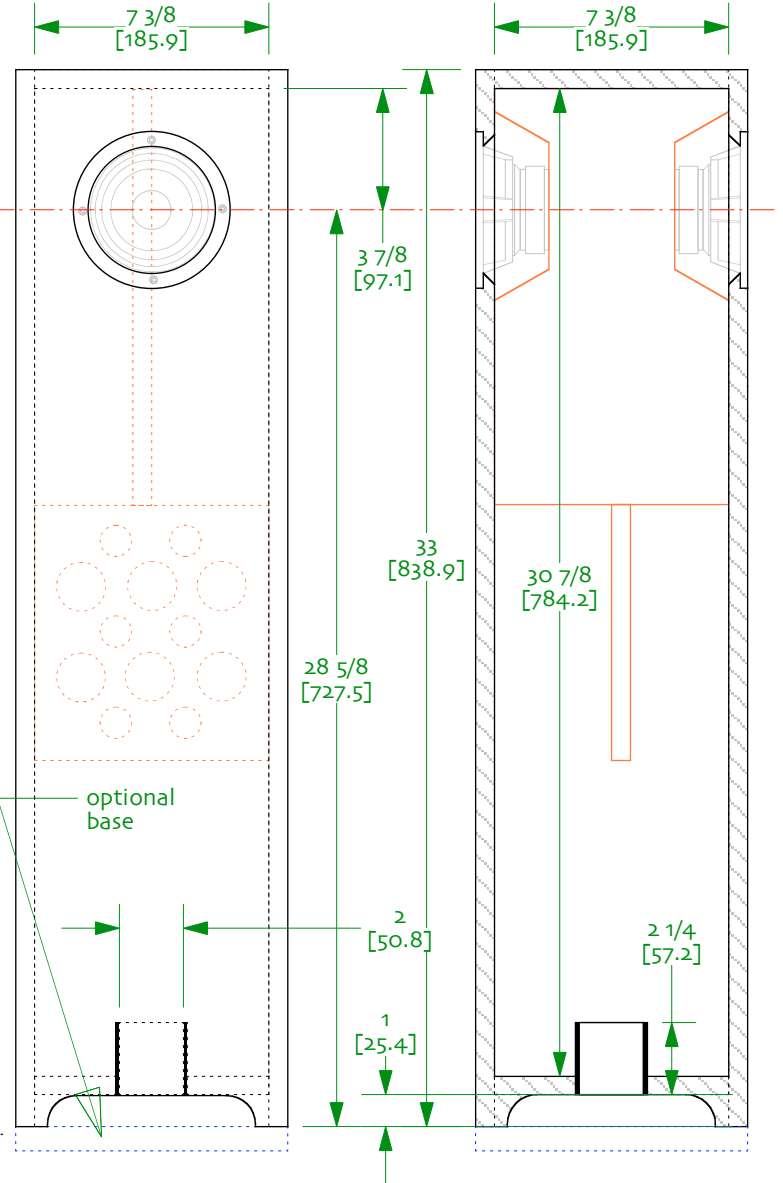
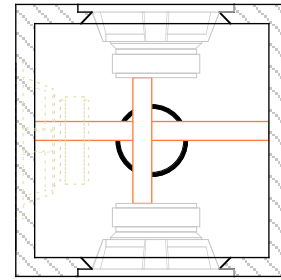
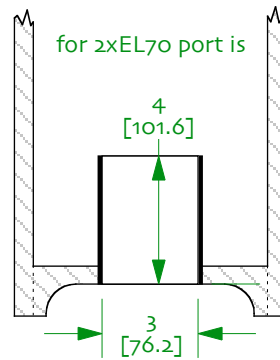
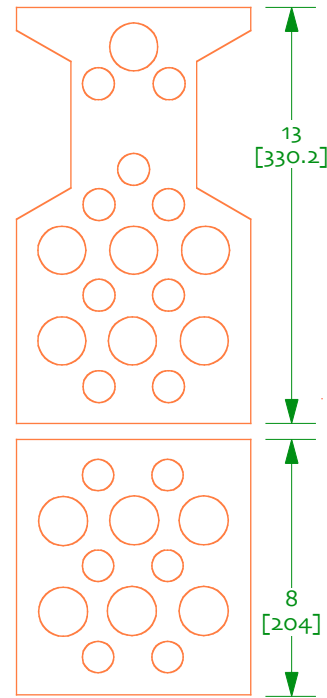
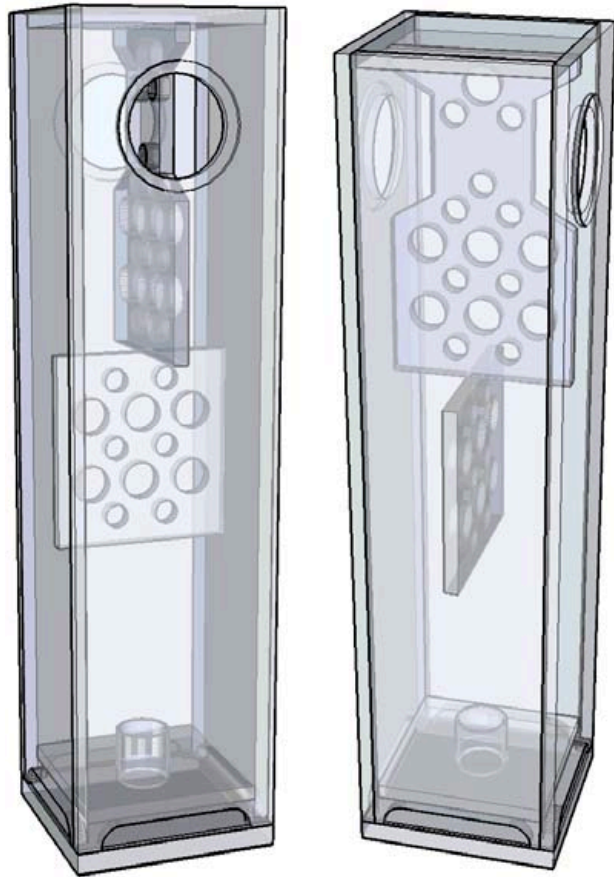

microTower 1v0

for 2 x Mark Audio CHR-70 or CSS EL70  
 15 - sep -2009 designed by dld sl | drawn by dld  
 © 2009 planet\_10 enterprises limited  
 free for non-commercial use

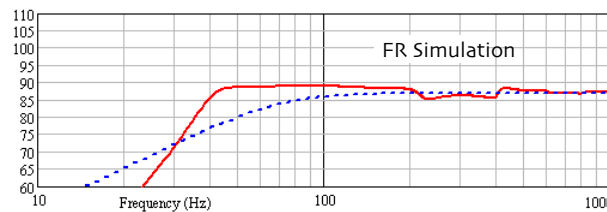



# CHR/EL70 microTower v0.92

variations on a theme

11 - aug-2009 designed by dld sl | drawn by dld  
© 2009 planet\_10 enterprises limited  
free for non-commercial use

### Notes:

- 0/ I had suggested a "castle-like" box for the CHR (left).
- 1/ from there it is not far from a BD-Pipe thing (middle Red/45°)
- 2/ or anywhere in between (middle orange 15°, blue 30° shown)
- 3/ within limited tip could be done the other way (left orange)

caveat -- this does change Zd.

4/ And what is stopping you from stacking 2 units per side.

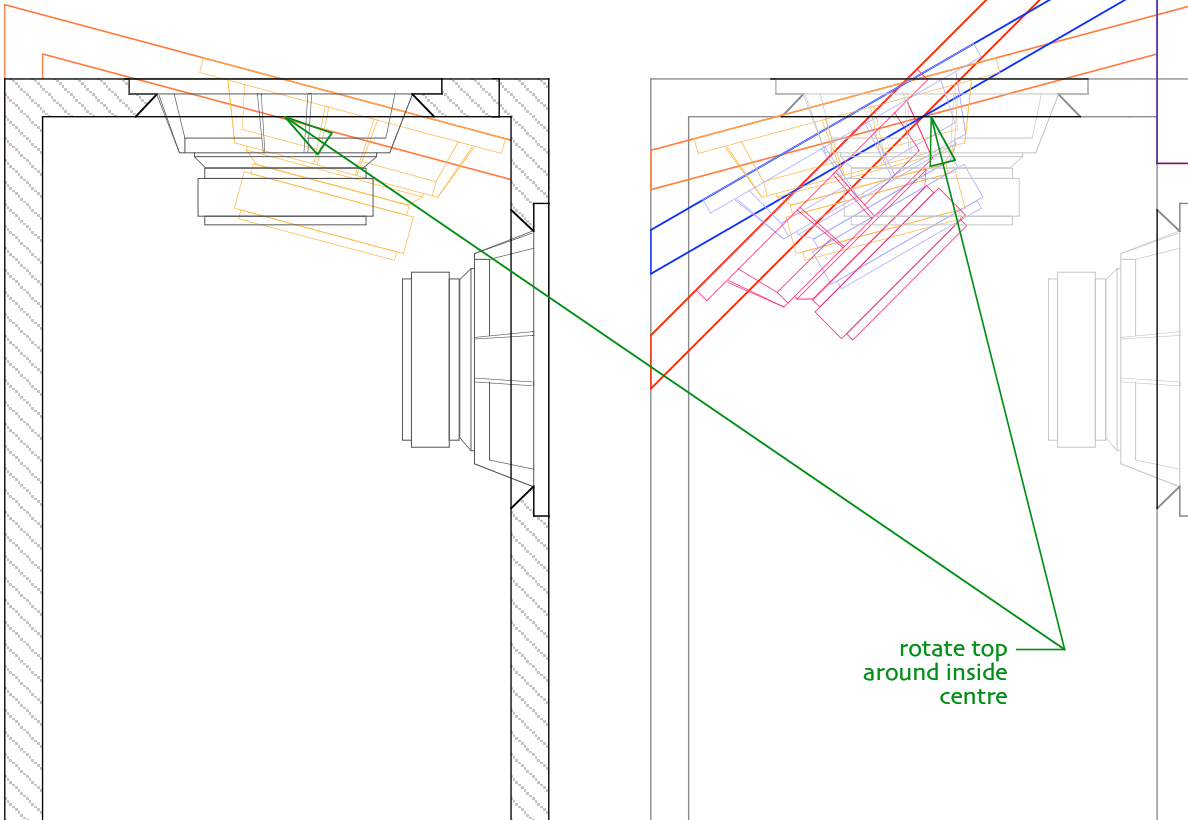
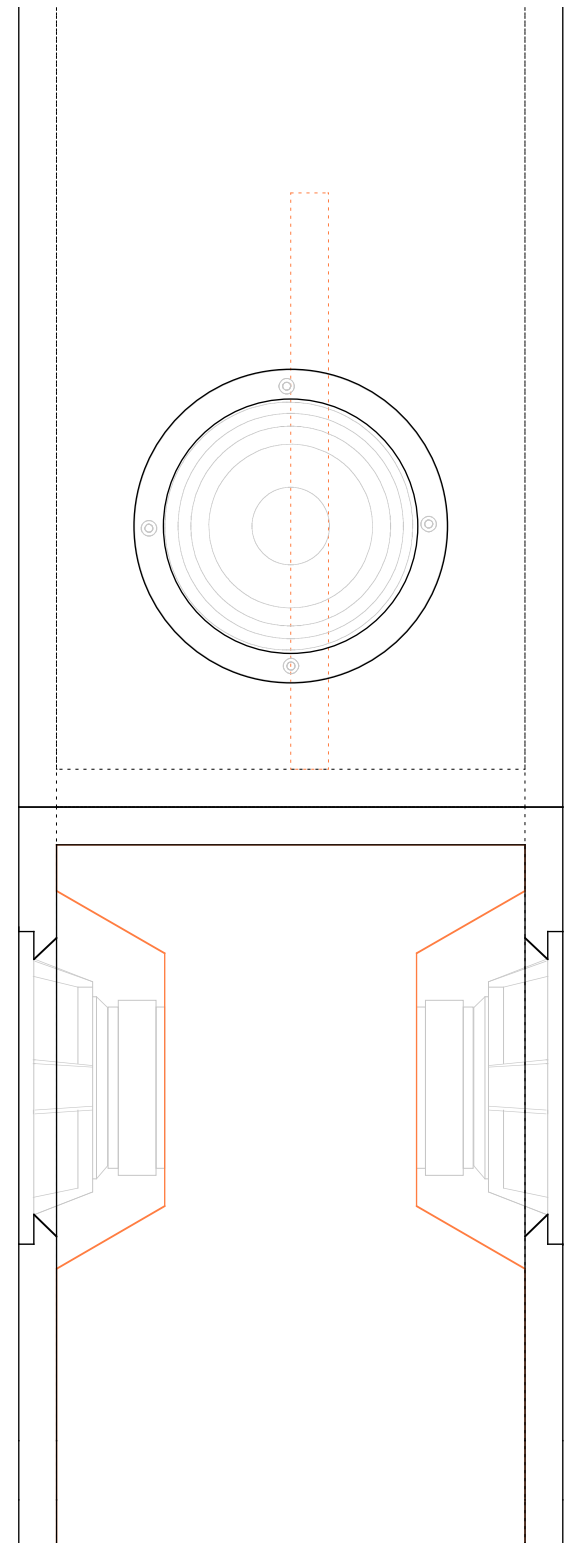
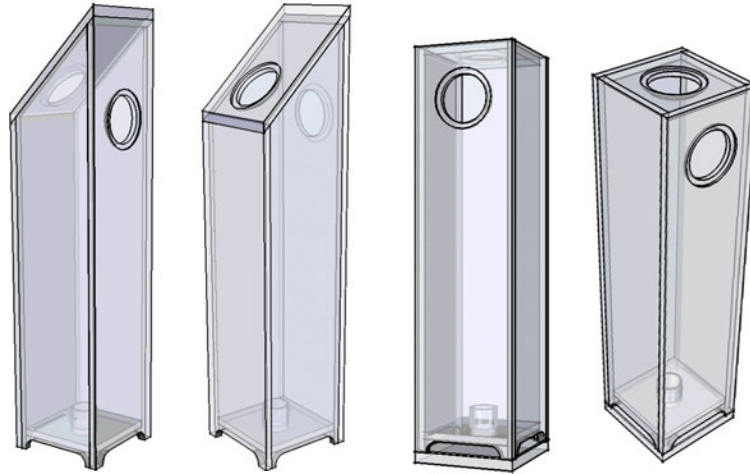

rotate top  
around inside  
centre



# chubbyTower v0.91

variations on a theme  
11 - aug -2009 designed by dld sl | drawn by dld  
© 2009 planet\_10 enterprises limited  
free for non-commercial use

- Notes:  
0/ drawn with 18mm material  
1/ these should probably be 18mm  
2/ twin 2" ports can be replaced by 1  
2.83" (72mm) port for the CHR-70.  
Port for the EL70 2x 3" D x 4" L or 1x  
4.24" D x 4" L  
3/ braces are holey (not shown in  
visualization)

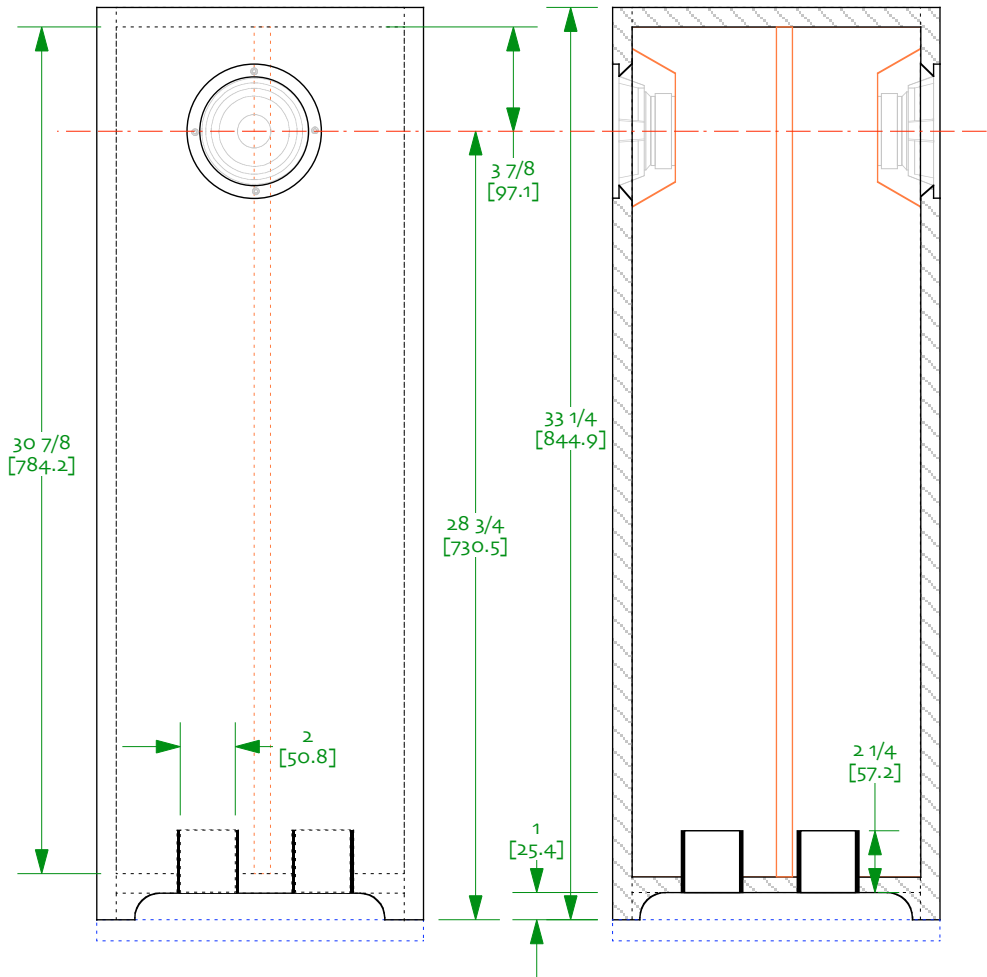
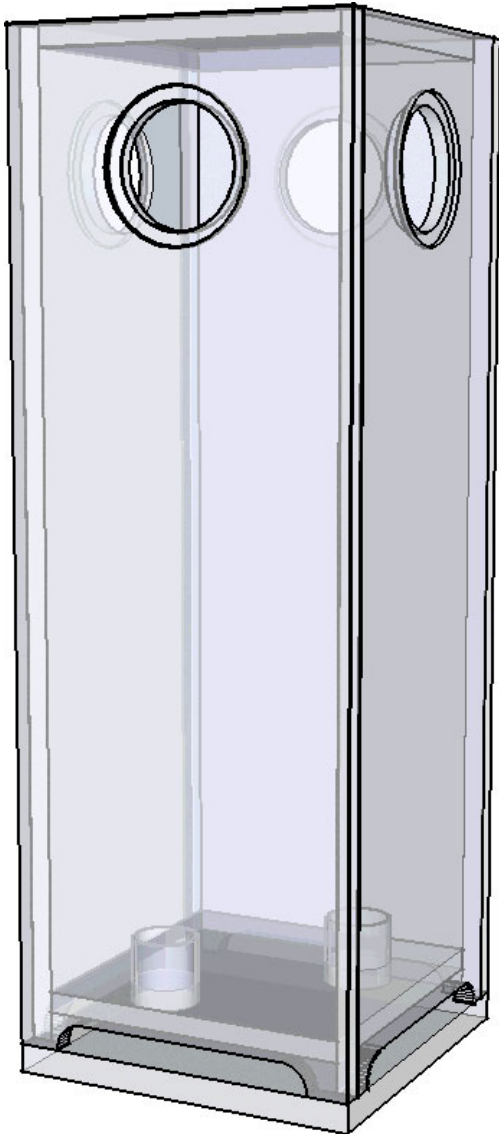
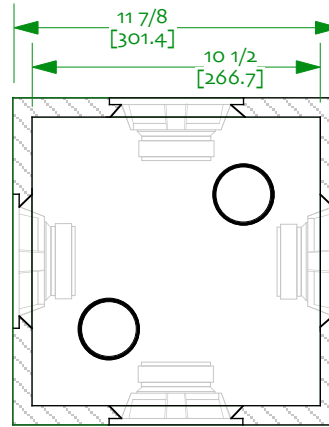

Notes:

- 0/ All panels 15mm (5/8") thick
- 1/ brace shape is only suggestive -- prime purpose is to brace speaker, it needs to be about 35-40% holes. (ie if you have to mount a terminal cup in the middle, you'll want to make sure the brace allows clearance)
- 2/ Don't forget to angle cut the back of the driver cut-out to give it breathing room
- 3/ Line top, back & 1 sidewall with 1" acoustic fiberglass, then tune to taste
- 4/ Port for the EL70 2" D x 5" L. Alternate port for the CHR 2" D x 6" L

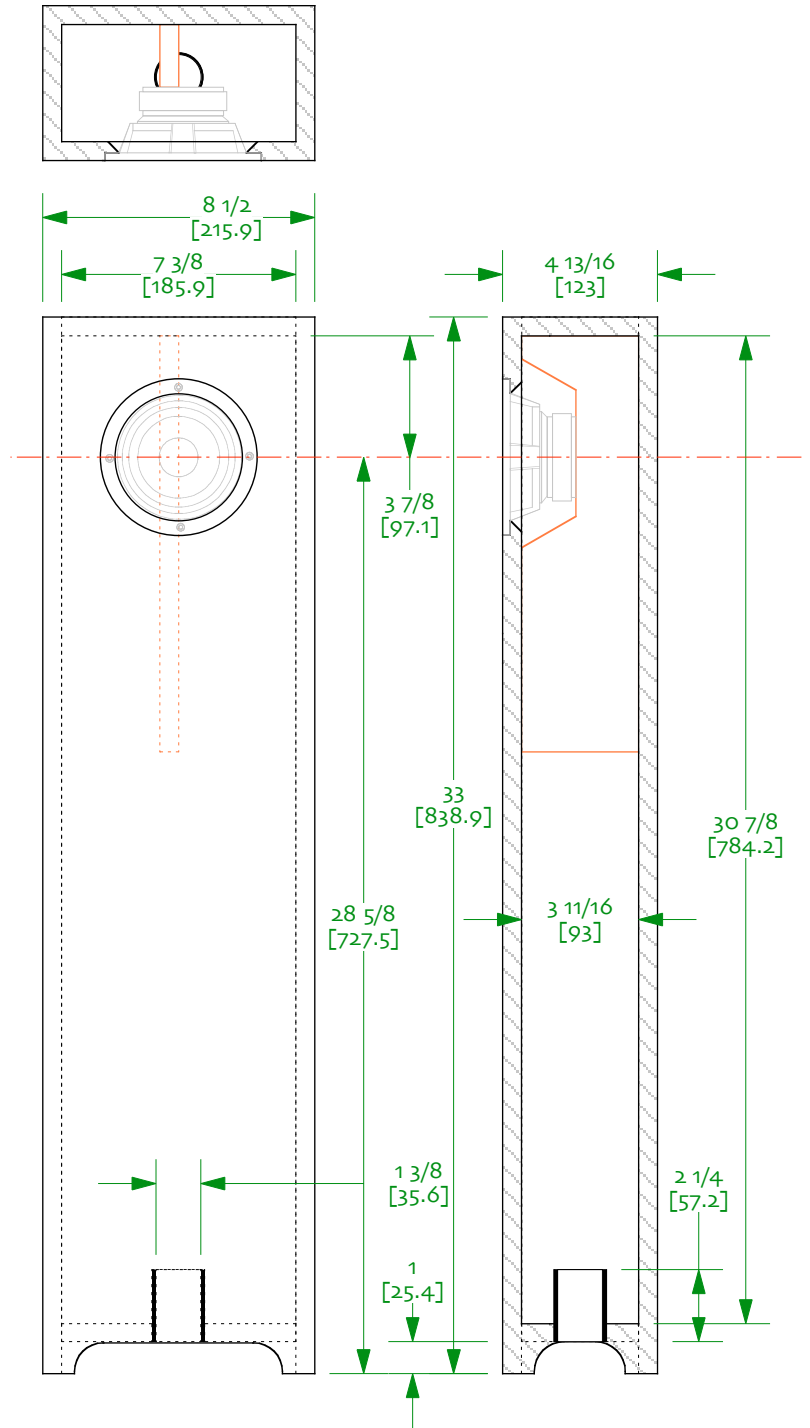
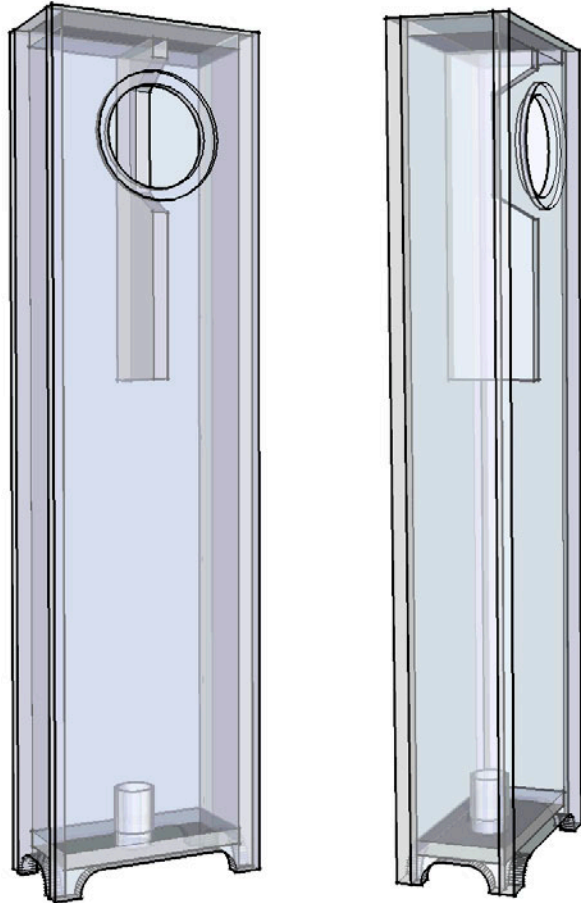

halfTower ML-TL v0.91

for Mark Audio CHR-70 or CSS EL70  
 12 - aug -2009 designed by dld sl | drawn by dld  
 © 2009 planet\_10 enterprises limited  
 free for non-commercial use

Notes:

- 0/ All panels 15mm (5/8") thick
- 1/ Line top, back & 1 sidewall with 1" acoustic fiberglass, then tune to taste
- 2/ top needs minimum 2" clearance for port
- 3/ Port for the EL70 2x 2.12" D x 4" L
- 4/ front bevels are optional

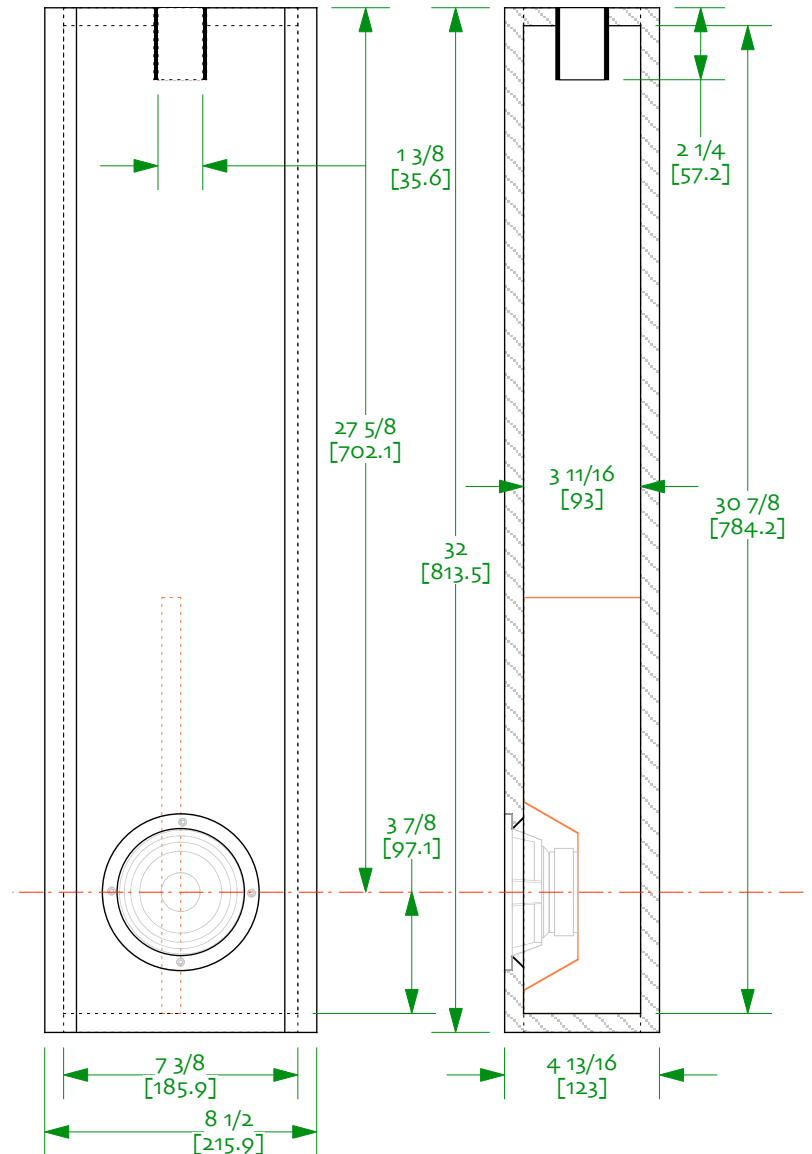
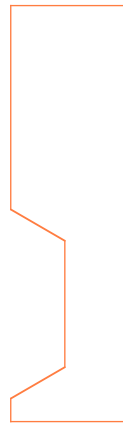
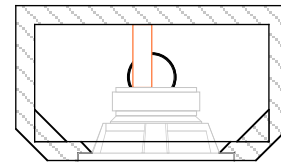
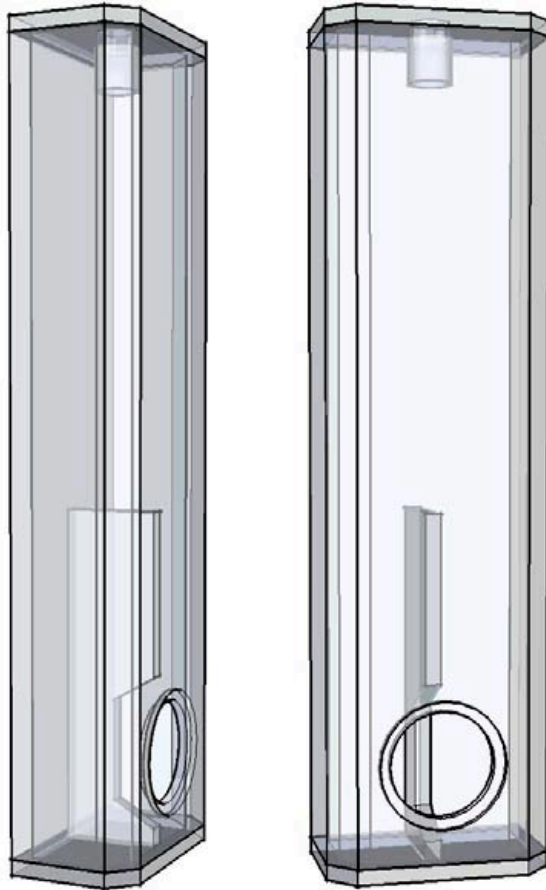

halfTower wallMount ML-TL v0.91

for Mark Audio CHR-70 or CSS EL70  
 12 - aug -2009 designed by dld sl | drawn by dld  
 © 2009 planet\_10 enterprises limited  
 free for non-commercial use

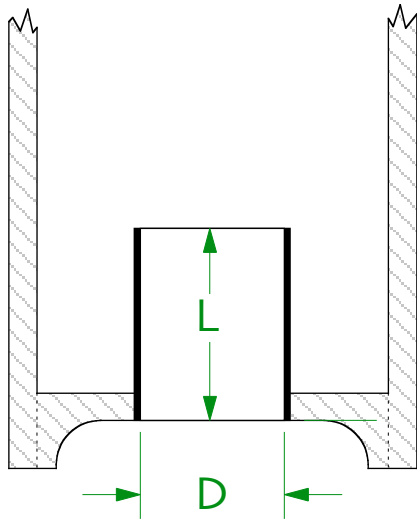

microTower	chubbyTower	halfTower
<b>CHR-70</b>	2 off	
2" (50.8mm) D 2 1/4" (57.2mm) L	2" (50.8mm) D 2 1/4" (57.2mm) L	1 3/8" (35.6mm) D 2 1/4" (57.2mm) L
	4" (101.6mm) D 4" (101.6mm) L	2" (50.8mm) D 6" (152.4mm) L
<b>EL70</b>	2 off	
3" (76.2mm) D 4" (101.6mm) L	3" (76.2mm) D 4" (101.6mm) L	2" (50.8mm) D 5" (128.0mm) L
	4.25" (108mm) D 4" (101.6mm) L	

equation to calculate vent lengths:

$$L_v = (23562.5 \cdot D_v^2 \cdot N_p / (F_b^2 \cdot V_b)) - (k \cdot D_v)$$

where,

- D<sub>v</sub> = port diameter (cm)
- F<sub>b</sub> = tuning frequency (Hz) = 42Hz
- V<sub>b</sub> = net volume (litres)
- L<sub>v</sub> = length of each port (cm)
- N<sub>p</sub> = number of ports
- k = end correction (normally 0.732)



microTower port variations

for Mark Audio CHR-70 or CSS EL70

15 - sep -2009 designed by dld sl | drawn by dld

© 2009 planet\_10 enterprises limited

free for non-commercial use

**Bipoles, Room Placement, and more** | A bipole needs some special consideration with room placement. The 2 primary benefits of a bipole are no baffle-step, and more reverberant energy pumped into the room. Both of these dictate that the bipole needs to be pulled out into the room. WRT baffle-step if too close to a wall, boundary reinforcement will lift the bass. WRT reverberant energy it is important that the reflections are delayed sufficiently to be beneficial. Although there is no specific time delay that is sufficient we can use 10ms (~11ft) as a figure of merit. If we also toe-in the speaker the reverberant energy can be bounced off the wall behind the speaker and that reflection off the wall, giving a longer path length/greater delay, and have it come from a direction that is the most beneficial to apparent source width and listener envelopment. (Floyd Toole's book "Sound Reproduction" goes into great detail) Another benefit accrues from toe-in. On-axis a bipole suffers a dip in FR with sound from the back speaker having to travel further. This happens just below the baffle-step frequency. The more toe-in, the smaller the dip, – if you toe the speakers to the point that you are on an axis perpendicular to the side of the cabinet it disappears completely. This dip is also filled in by reverberant energy and doesn't show up in the power response. Mounting the 2nd driver on the top or on the sides changes the way the reverberant energy gets into the room, as well as reducing the bipole dip by bringing the 2 drivers closer together. Baffle step compensation is not greatly affected.

So you will need to pull these out from the walls, possibly less so with side or top placement (Linn Isobariks with top firing drivers were to be used pushed up right against a wall) and play with the amount of toe-in – possibly more than you are used to.

**Recommended materials** | Baltic Birch or other near void-free plywood is highly recommended. The more plies the better – 15mm Baltic Birch has 11 plies. Plywood has been selected for the combination of its higher stiffness to weight ratio, well demonstrated advantages of speed of dissipation of resonances when compared to denser materials such as MDF or HDF, as well as its lower mass.

**Driver wiring** | For the twin driver versions, series wiring is recommended; however parallel is possible providing the amp can cope with the very low impedance. Of course you can use 2 amplifiers as well. Locations and type of input terminals not shown, use your favorite.

**Alternate material thicknesses** | All these designs have been drawn with nominal 15mm (5/8") material. As noted above, typical 11 ply Baltic Birch is 15mm. Note that material thickness can vary from sheet to sheet within a lift of material, so it is important to check and to vary lengths of panels to avoid surprises. Maintain internal size. If you have no alternative but to use MDF or particleboard, it is strongly suggested that the side panels have additional pieces laminated to achieve 1" - 1 1/8" to increase the stiffness to ~equal that of BB ply.

**Driver Cutouts** | Although all drawings show a bevel on the back of the driver cutout, our work with several initial prototypes using CHR & EL70 drivers suggest that due to the width and thickness of the mounting flange, beveling the back side of the driver cut out may not be appropriate with thinner baffle materials (ie 15mm), or if the driver is rebated for flush mounting

### Holey Braces

1) Critical to the function of the driver holey brace is for it to transmit driver energy away from the baffle. It should fit tight against driver, but not so tight as to stress the frame.

2) Braces are placed just off-centre – ie on one side of the cabinet or driver centre line.

3) Dimensions & placement of holes in bracing panels are only suggestive. Goal is 30-40% holes, leaving a solid path between back of driver to back of cab (or other driver). More bracing than shown or interlocked braces is OK. Avoid braces that are parallel to the back of the driver in the vicinity of the driver.

**Other drivers** | Inevitably, people ask if they can use alternate drivers. These boxes were designed specifically for the T/S parameters and physical dimensions of the EL70 & CHR-70. Drivers with very similar Theile/Small parameters may work, but you are on your own.

**Damping Materials** | The original EPI microTower used a single chunk of 3 or 4" thick fiberglass placed diagonally across the line for the entire length of the cabinet. In our actual builds we emulated this, but used a recycled denim cotton house insulation material (3") in the line below the driver. The walls around the drivers were lined with a similar material 1/2" thick and a small amount of polyfluff placed in the space between the drivers,

Other damping schemes should work well including the original EPI technique and others such as lining the walls (holey braces are also candidates) with wool or cotton felt, acoustic foam, or fiberglass insulation, space filling with polyfluff, acoustistuff, or real wool, or a combination. The port can also have stuffing placed in it if you find you are getting too much bass energy.

The amount and placement of damping will affect the quantity of LF and are subject to experimentation to fine-tune individual system synergy – ie room, amplifier used, materials used, taste.

**Tightening driver mounting screws** | The polymer material used in the Mark Audio once piece moulded basket/flange requires the use of caution when tightening the mounting screws – preferably by hand not with cordless drill. Sonically just the right amount of torque on the screws has an effect. Screws should be just tight enough to hold a real or imaginary washer from being turned.

**Rights to Designs** | microTower Series cabinets copyright 2009 Planet10-HiFi. All rights reserved. Provided for non-commercial use only. Commercial enquires please contact Planet10-HiFi

Designs all pass through Martin J. King MathCAD worksheets <[www.quarter-wave.com](http://www.quarter-wave.com)> Any commercial licensees will be required to have a separate commercial license to this software.

Of course feel free to exercise personal taste in both the finishing of cabinets and use of mounting spikes, bases, etc.

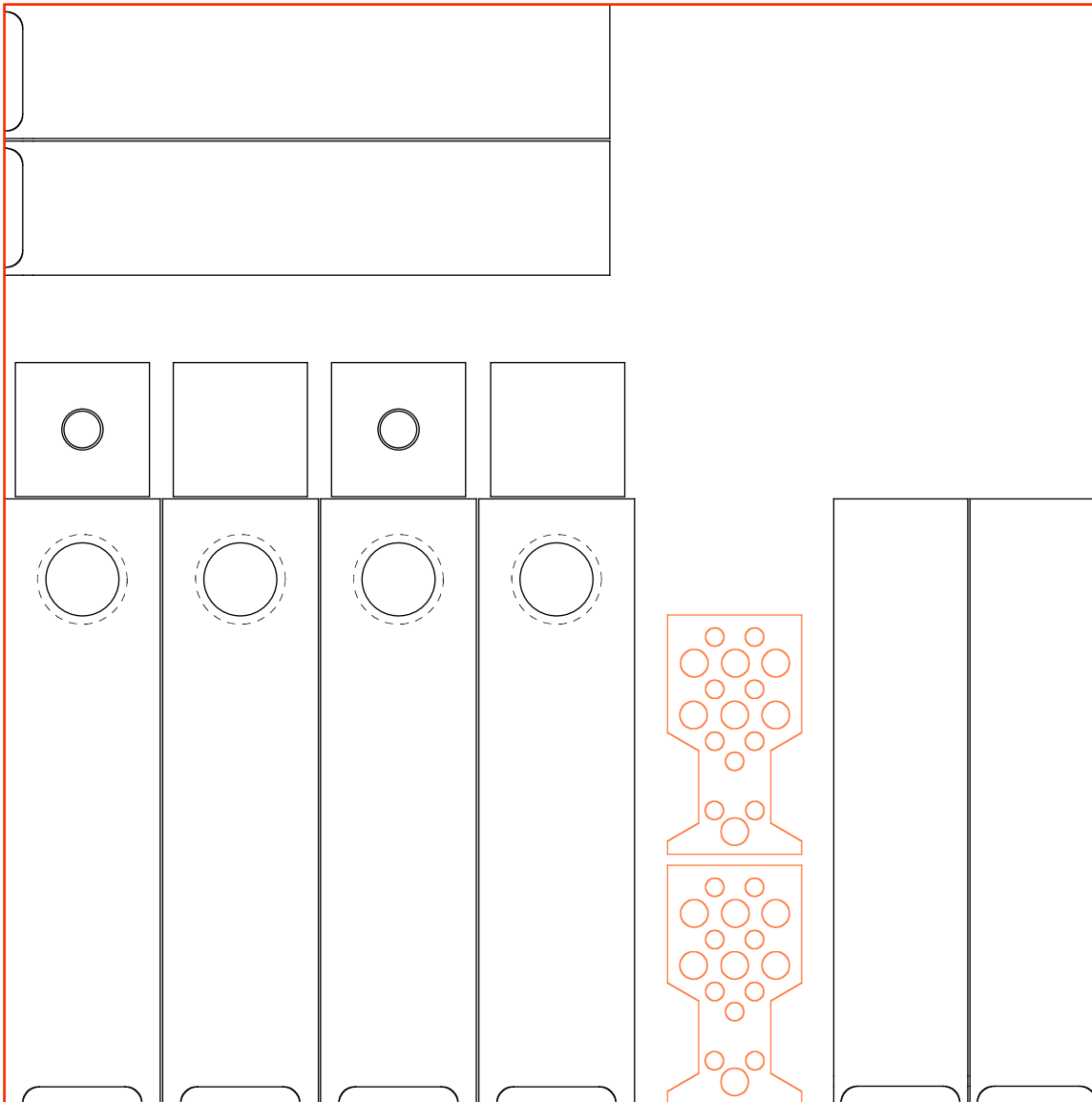

Notes:

1) 1/8" kerf allowance. Lots of room for larger kerf

2) Driver panels are full width, layout for simple butt joints.

3) The location of bottom panel and driver brace are entirely arbitrary - as these are not visible, they could be taken from anywhere on the sheet, and even for that matter of different material.

3) The 5x5 pattern assumes that builders would not have surplus off-cuts to achieve vertical grain direction of all 8 sides, AND that if finishing the cabinets in a clear or grain transparent stain & top coats, are willing to accept one panel with horizontal grain. There is simply no way to get the same grain direction on all 8 side panels pieces from a single 5x5 sheet.



microTower v0.92

cut plan #1 for 5x5 BB & butt joints

12- aug -2009 drawn by dld

© 2009 planet\_10 enterprises limited  
free for non-commercial use

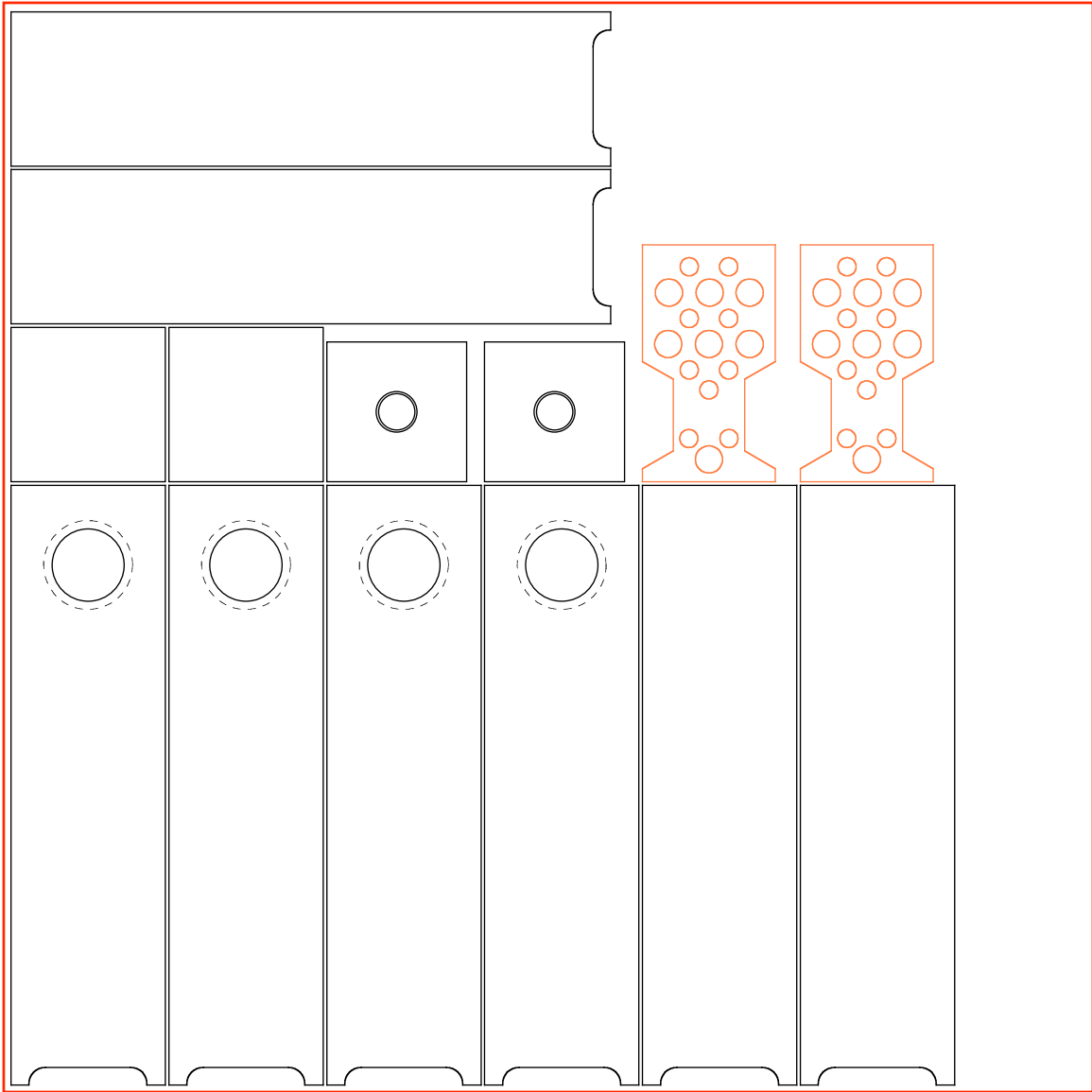

Notes:

1) The plans attached are for maximum yield, and include kerf and trim cut allowances for our production saws (5mm and 10mm respectively) that DIYers could reduce, but without significant effect on the yield or pattern.

2) All panels are full width, assuming either 45 bevel or lock joints. There are numerous other possible joinery methods - dado or simple butt joints, ncluding either dowels or biscuits could reduce the width of any or all panels. The bottom panel is assumed to be dadoed in by 5mm on all edges, the driver brace is not. Neither does the pattern show alternative locations of magnet cut-outs for "Castle Howard" variant.

3) Assumes that builders would not have surplus off-cuts to achieve vertical grain direction of all 8 sides, AND that if finishing the cabinets in a clear or grain transparent stain & top coats, are willing to accept one panel with horizontal grain. There is simply no way to get the same grain direction on all 8 side panels pieces from a single 5x5 sheet.



microTower v0.92

cut plan #2 for 5x5 BB  
 12- aug -2009 drawn by dld  
 © 2009 planet\_10 enterprises limited  
 free for non-commercial use

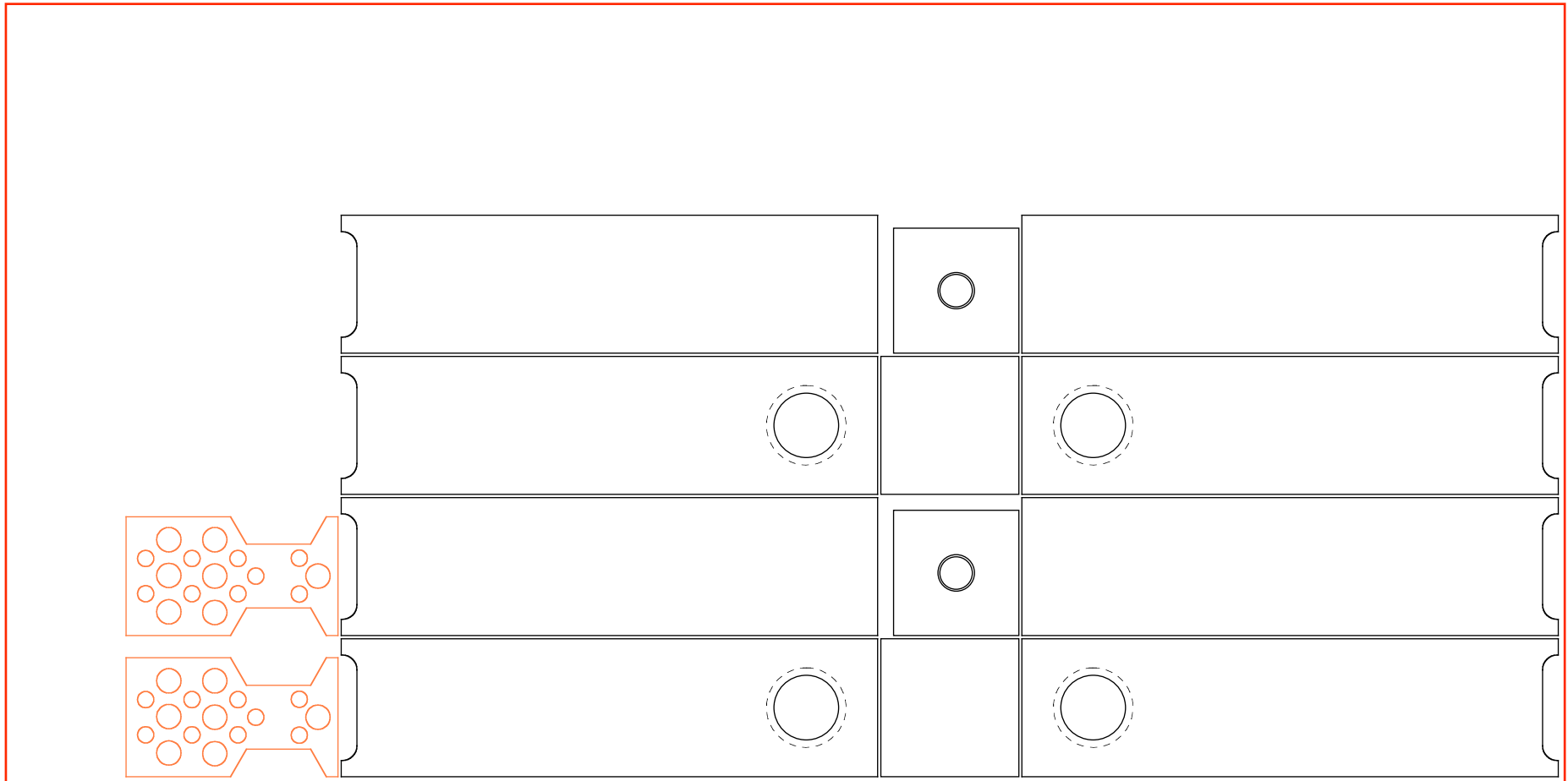

Notes:

1) The plans attached are for maximum yield, and include kerf and trim cut allowances for our production saws (5mm and 10mm respectively) that DIYers could reduce, but without significant effect on the yield or pattern.

2) All panels are full width, assuming either 45 bevel or lock joints. There are numerous other possible joinery methods - dado or simple butt joints, including either dowels or biscuits could reduce the width of any or all panels. The bottom panel is assumed to be dadoed in by 5mm on all edges, the driver brace is not. Neither does the pattern show alternative locations of magnet cut-outs for "Castle Howard" variant.

3) The location of bottom panel and driver brace are entirely arbitrary – as these are not visible, they could be taken from anywhere on the sheet, and even for that matter of different material. This layout also applicable for veneer applied post assembly, and caveats re yield due to pattern wrapping apply.



microTower v0.92

cut plan #3 for 4x8 multi-ply  
 12- aug -2009 drawn by dld  
 © 2009 planet\_10 enterprises limited  
 free for non-commercial use