

WIRING DIAGRAMS

Article Text

1989 Toyota Supra

For www.jarwhite.ru

Copyright © 1998 Mitchell Repair Information Company, LLC

Tuesday, July 30, 2002 04:05PM

ARTICLE BEGINNING

1989 WIRING DIAGRAMS
Toyota Wiring Diagrams

Supra

IDENTIFICATION

COMPONENT LOCATION MENU

COMPONENT LOCATIONS TABLE

AA

| Component | (Figure No.) | Location |
|---------------------------|--------------|-----------|
| A/C AMPLIFIER | (8) | C 28 |
| A/C RELAY BOX | (8) | D-E 31 |
| A/T IND SW | (9) | E 35 |
| ABS ACTUATOR | (10) | D-E 36 |
| ABS COMPUTER | (10) | D-E 39 |
| ALTERNATOR | (1) | B 3 |
| AUTO ANTENNA MOTOR | (12) | D 46 |
| BACK-UP LT SW | (12) | C 47 |
| BATTERY | (1) | A 2 |
| BLOWER MOTOR | (8) | E 30 |
| BLOWER RESISTOR | (8) | E 29 |
| CHECK CONN (7M-GE) | (2) | E 4 |
| CHECK CONN (7M-GTE) | (3) | D-E 11 |
| CHOKE COIL | (12) | C 46 |
| CLUTCH SW | (9) | C 35 |
| COLD START INJECTOR | (1) | B 3 |
| CONDENSER FAN RELAYS | (8) | C-D 29-30 |
| COOLANT VSV | (8) | B 29 |
| CRUISE CONTROL ACTUATOR | (9) | C 35 |
| CRUISE CONTROL COMPUTER | (9) | A 34 |
| CRUISE CONTROL MAIN RELAY | (9) | B 35 |
| DEFOG SW | (11) | D 40 |
| DIODE (7M-GTE) | (11) | C 41 |
| DIR SW | (11) | A 40 |
| DOOR KEY CYLINDER LT | (7) | C 27 |
| DOOR LOCK CTRL RELAY | (10) | A 37 |
| ECT ECU | (9) | D-E 32 |
| ECT SOLENOID | (9) | D 35 |
| EFI RESISTOR (7M-GTE) | (3) | E 8 |
| FOG LT RELAY | (6) | C 20 |
| FUEL PUMP RLY (7M-GE) | (2) | D 4 |
| FUEL PUMP RLY (7M-GTE) | (3) | A 10 |
| HAZARD SW | (11) | B 40 |
| HEADLT CLEANER MOTOR | (1) | D 3 |
| HEADLT CLEANER RELAY | (1) | D 3 |
| HEADLT CLEANER SW | (1) | D 3 |

WIRING DIAGRAMS

Article Text (p. 2)

1989 Toyota Supra

For www.jarwhite.ru

Copyright © 1998 Mitchell Repair Information Company, LLC

Tuesday, July 30, 2002 04:05PM

| | | | |
|---------------------------------|-------|-----|-----------------|
| HEADLT SW | (11) | C | 40 |
| HEATER CONTROL ASSEMBLY | (8) | A | 29-30 |
| IGNITER (7M-GTE) | (3) | E | 9-10 |
| IGNITER ASSEMBLY (7M-GE) | (2) | E | 7 |
| IGNITION SW | (5) | D | 19 |
| INSTRUMENT CLUSTER | (11) | A-E | 43 |
| INTERIOR LT | (11) | E | 42 |
| J/B #1 | (4,5) | B-E | 13-14/A-E 17-18 |
| J/B #2 | (6) | D-E | 21-22 |
| J/B #3 | (7) | A-B | 25-26 |
| J/B #7 | (7) | C-D | 25-26 |
| LEFT DOOR KEY SW | (7) | E | 24 |
| LEFT FRONT TEMS ACTUATOR | (9) | B | 32 |
| LEFT/RIGHT TEMS ACTUATORS | (12) | E | 44-45 |
| LT FAILURE SENSOR | (12) | E | 47 |
| LT RETAINER/RETRACT CTRL RLY | (1) | D-E | 3 |
| MAGNET CLUTCH RELAY | (8) | D | 29 |
| MIRROR HEATERS | (10) | B | 39 |
| O/D MAIN SW | (9) | D | 32 |
| PATTERN SELECT SW | (9) | C | 35 |
| POWER MIRROR SW | (10) | A | 39 |
| POWER SEATS | (12) | A | 44-47 |
| POWER WINDOW SW | (12) | B-C | 44-45 |
| PPS COMPUTER | (10) | B | 37 |
| R/B #4 | (6) | A-B | 22 |
| R/B #5 | (6) | A-B | 20 |
| REAR WIPER ASSEMBLY | (12) | D | 44 |
| RIGHT DOOR LOCK SW | (10) | C | 36 |
| RIGHT DOOR SOLENOID | (10) | B | 36 |
| SHIFT LOCK CTRL COMPUTER | (10) | B | 39 |
| STOP LT SW | (10) | C | 39 |
| TCCS ECU (7M-GE) | (2) | A | 4-7 |
| TCCS ECU (7M-GTE) | (3) | A-E | 8 |
| TEMS COMPUTER | (9) | A | 33 |
| THEFT DETERRENT COMPUTER | (7) | E | 27 |
| THROTTLE POSITION SENS (7M-GE) | (2) | C | 4 |
| THROTTLE POSITION SENS (7M-GTE) | (3) | A | 8 |
| UNLOCK WARN SW | (10) | B | 37 |
| VANITY MIRROR LT | (11) | D | 42 |
| WASHER MOTOR | (1) | C | 1 |
| WIPER MOTOR | (1) | C | 2 |
| WIPER RELAY | (1) | C | 3 |
| WIPER/WASHER SW | (11) | E | 40 |

AA

WIRING DIAGRAMS

Article Text (p. 3)

1989 Toyota Supra

For www.jarwhite.ru

Copyright © 1998 Mitchell Repair Information Company, LLC

Tuesday, July 30, 2002 04:05PM

COMPONENT LOCATOR:

| | | |
|---------------------------------|-------|---------------------|
| A/C AMPLIFIER | | C 28 |
| A/C RELAY BOX | | D-E 31 |
| A/T IND SW | | E 35 |
| ABS ACTUATOR | | D-E 36 |
| ABS COMPUTER | | D-E 39 |
| ALTERNATOR | | B 3 |
| AUTO ANTENNA MOTOR | | D 46 |
| BACK-UP LT SW | | D 47 |
| BATTERY | | A 2 |
| BLOWER MOTOR | | E 30 |
| BLOWER RESISTOR | | E 29 |
| CHECK COIN (7M-GE) | | E 4 |
| CHECK COIN (7M-GTE) | | D-E 11 |
| CHOKO COIL | | C 46 |
| CLUTCH SW | | C 35 |
| COLD START INJECTOR | | B 3 |
| CONDENSER FAN RELAYS | | C D 29-30 |
| COOLANT VSV | | B 29 |
| CRUISE CONTROL ACTUATOR | | C 35 |
| CRUISE CONTROL COMPUTER | | A 34 |
| CRUISE CONTROL MAIN RELAY | | B 35 |
| DEFOG SW | | D 40 |
| DIODE (7M-GTE) | | C 41 |
| DIR SW | | A 40 |
| DOOR KEY CYLINDER LT | | C 27 |
| DOOR LOCK CTRL RELAY | | C 27 |
| ECT ECU | | D-E 32 |
| ECT SOLENOID | | D 35 |
| EPI RESISTOR (7M-GTE) | | E 8 |
| FOG LT RELAY | | C 20 |
| FUEL PUMP RLY (7M-GE) | | D 4 |
| FUEL PUMP RLY (7M-GTE) | | A 10 |
| HAZARD SW | | B 40 |
| HEADLT CLEANER MOTOR | | D 3 |
| HEADLT CLEANER RELAY | | D 3 |
| HEADLT CLEANER SW | | C 40 |
| HEADLT SW | | C 40 |
| HEATER CONTROL ASSEMBLY | | A 29-30 |
| IGNITER (7M-GTE) | | E 9-10 |
| IGNITER ASSEMBLY (7M-GE) | | E 7 |
| IGNITION SW | | D 19 |
| INSTRUMENT CLUSTER | | A-E 42 |
| INTERIOR LT | | B-E 13-14/A-E 17-18 |
| J/B #1 | | B-E 13-14/A-E 17-18 |
| J/B #2 | | D-E 21-22 |
| J/B #3 | | A-B 25-26 |
| J/B #7 | | C-D 25-26 |
| LEFT DOOR KEY SW | | E 24 |
| LEFT FRONT TEMS ACTUATOR | | B 32 |
| LEFT/RIGHT TEMS ACTUATORS | | E 44-45 |
| LT FAILURE SENSOR | | E 47 |
| LT RETAINER/RETRACT CTRL RLY | | D-E 3 |
| MAGNET CLUTCH RELAY | | D 29 |
| MIRROR HEATERS | | B 39 |
| O/D MAIN SW | | C 32 |
| PATTERN SELECT SW | | C 35 |
| POWER MIRROR SW | | A 39 |
| POWER SEATS | | A 44-47 |
| POWER WINDOW SW | | B-C 44-45 |
| PPS COMPUTER | | B 37 |
| R/B #4 | | A-B 22 |
| R/B #5 | | A-B 20 |
| REAR WIPER ASSEMBLY | | D 44 |
| RIGHT DOOR LOCK SW | | C 36 |
| RIGHT DOOR SOLENOID | | B 36 |
| SHIFT LOCK CTRL COMPUTER | | B 39 |
| STOP LT SW | | C 39 |
| TCCS ECU (7M-GE) | | A 4-7 |
| TCCS ECU (7M-GTE) | | A-E 8 |
| TEM COMPUTER | | A 33 |
| THEFT DETERRENT COMPUTER | | E 27 |
| THROTTLE POSITION SENS (7M-GE) | | C 4 |
| THROTTLE POSITION SENS (7M-GTE) | | A 8 |
| UNLOCK WARN SW | | B 37 |
| VANITY MIRROR LT | | D 42 |
| WASHER MOTOR | | C 1 |
| WIPER MOTOR | | C 3 |
| WIPER/WASHER SW | | E 40 |

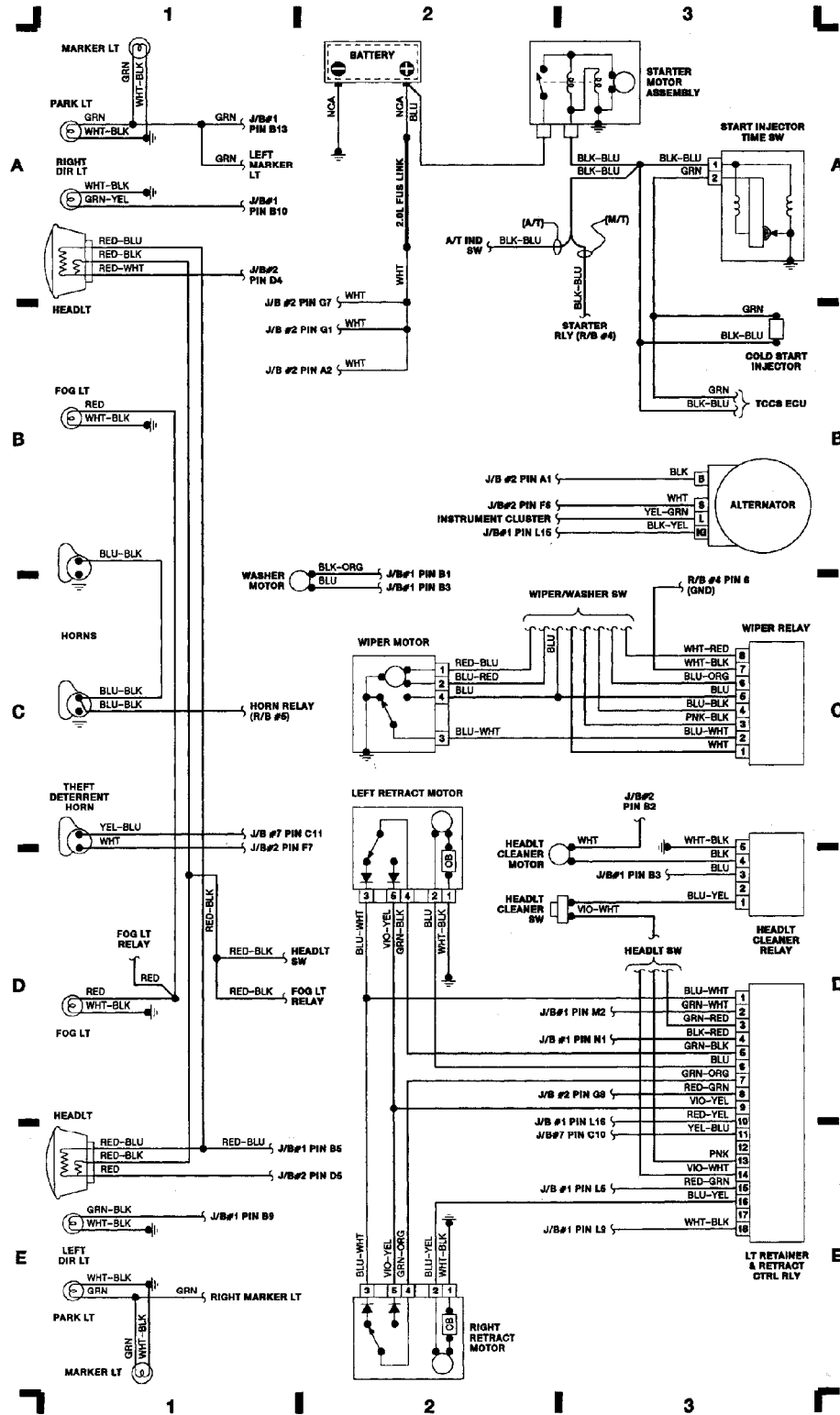

90B07361
Fig. 1: Engine Compartment & Headlights

WIRING DIAGRAMS

Article Text (p. 4)

1989 Toyota Supra

For www.jarwhite.ru

Copyright © 1998 Mitchell Repair Information Company, LLC

Tuesday, July 30, 2002 04:05PM

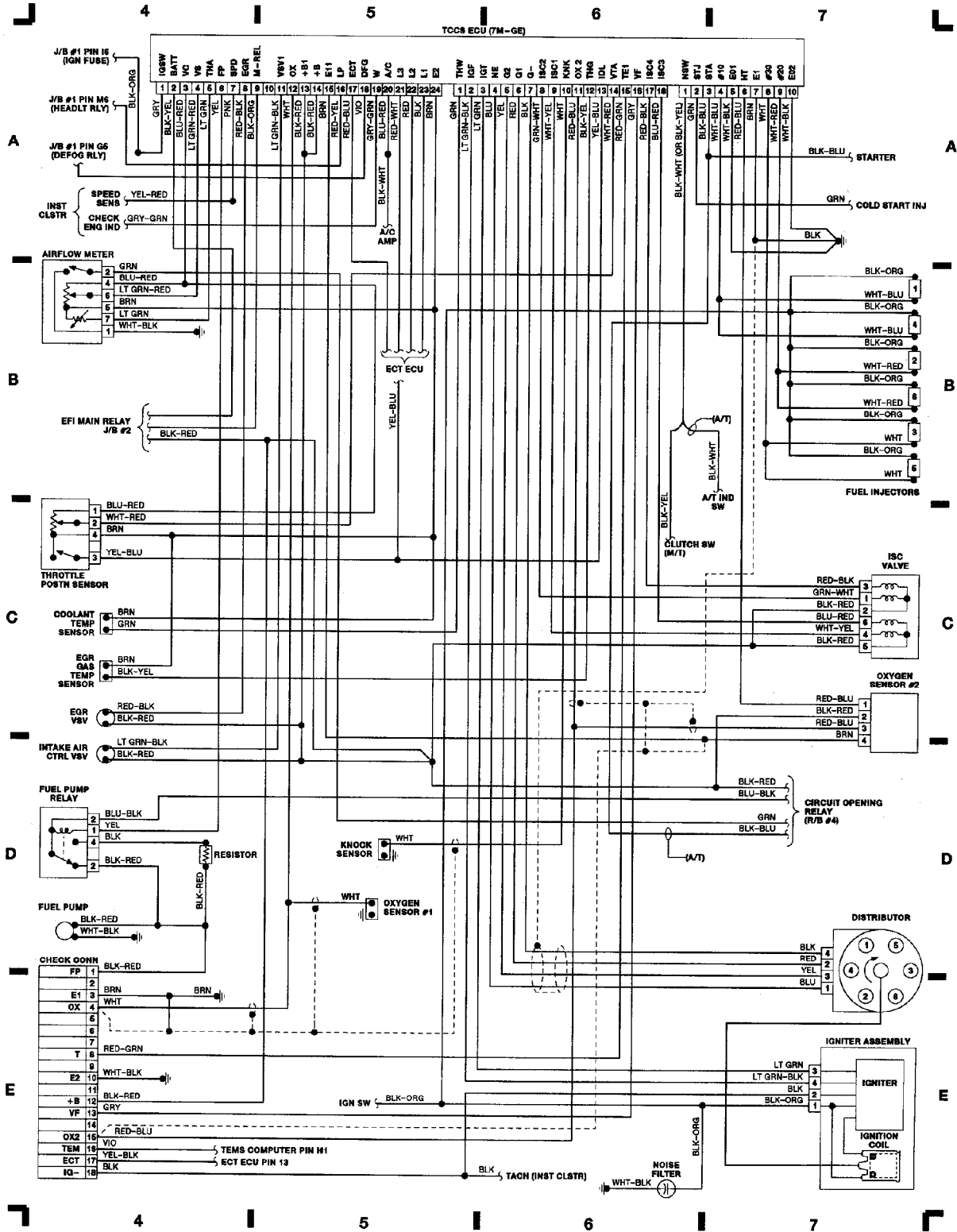

90D07362
Fig. 2: Computer Engine Control (Non-Turbo)

WIRING DIAGRAMS
Article Text (p. 5)
 1989 Toyota Supra
 For www.jarwhite.ru
 Copyright © 1998 Mitchell Repair Information Company, LLC
 Tuesday, July 30, 2002 04:05PM

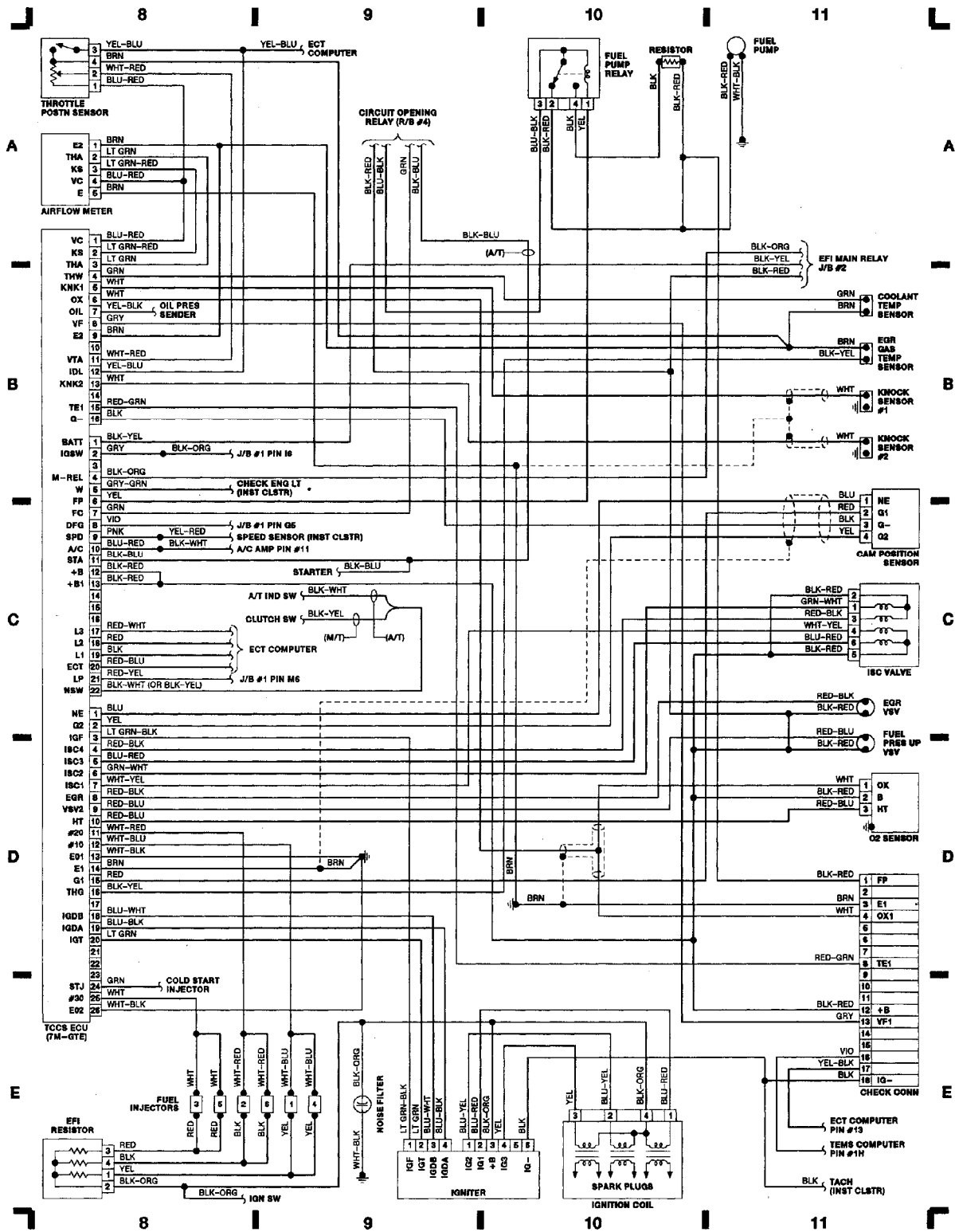

90F07363
 Fig. 3: Computer Engine Control (Turbo)

WIRING DIAGRAMS

Article Text (p. 6)

1989 Toyota Supra

For www.jarwhite.ru

Copyright © 1998 Mitchell Repair Information Company, LLC

Tuesday, July 30, 2002 04:05PM

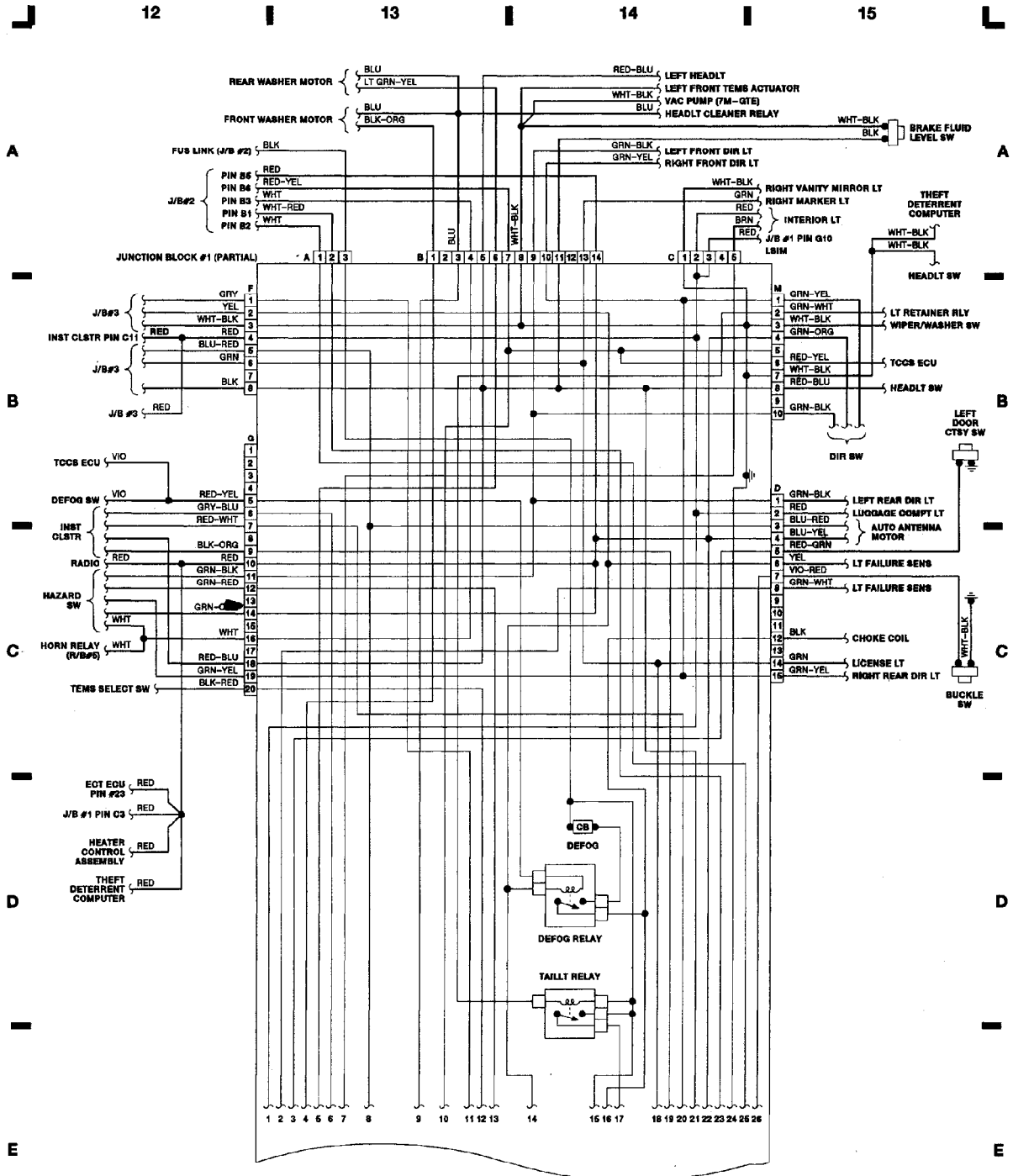

90H07364
Fig. 4: Fuse Block No. 1 (1 of 2)

WIRING DIAGRAMS
Article Text (p. 7)
 1989 Toyota Supra
 For www.jarwhite.ru
 Copyright © 1998 Mitchell Repair Information Company, LLC
 Tuesday, July 30, 2002 04:05PM

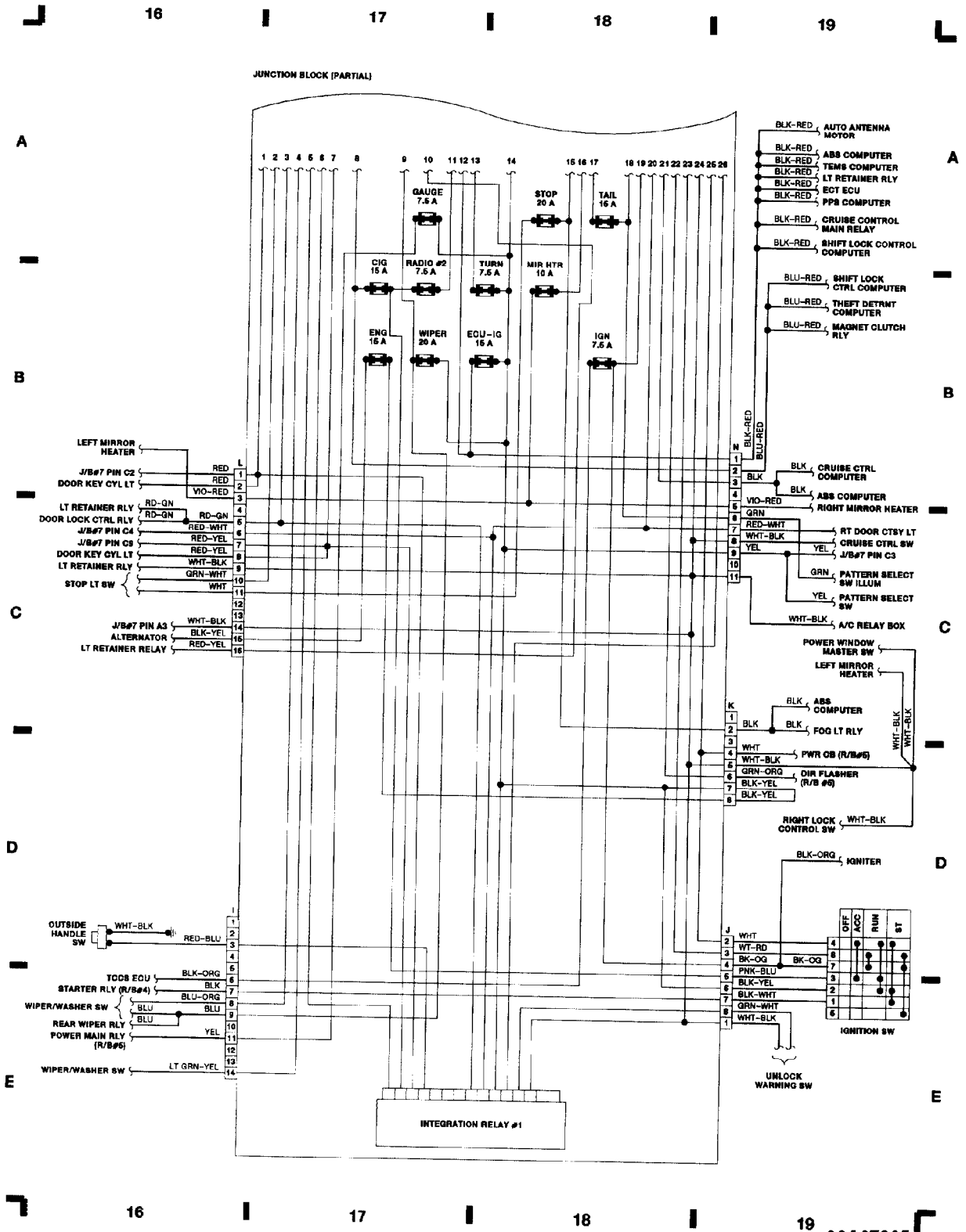

Fig. 5: Fuse Block No. 1 (2 of 2)

WIRING DIAGRAMS

Article Text (p. 8)

1989 Toyota Supra

For www.jarwhite.ru

Copyright © 1998 Mitchell Repair Information Company, LLC

Tuesday, July 30, 2002 04:05PM

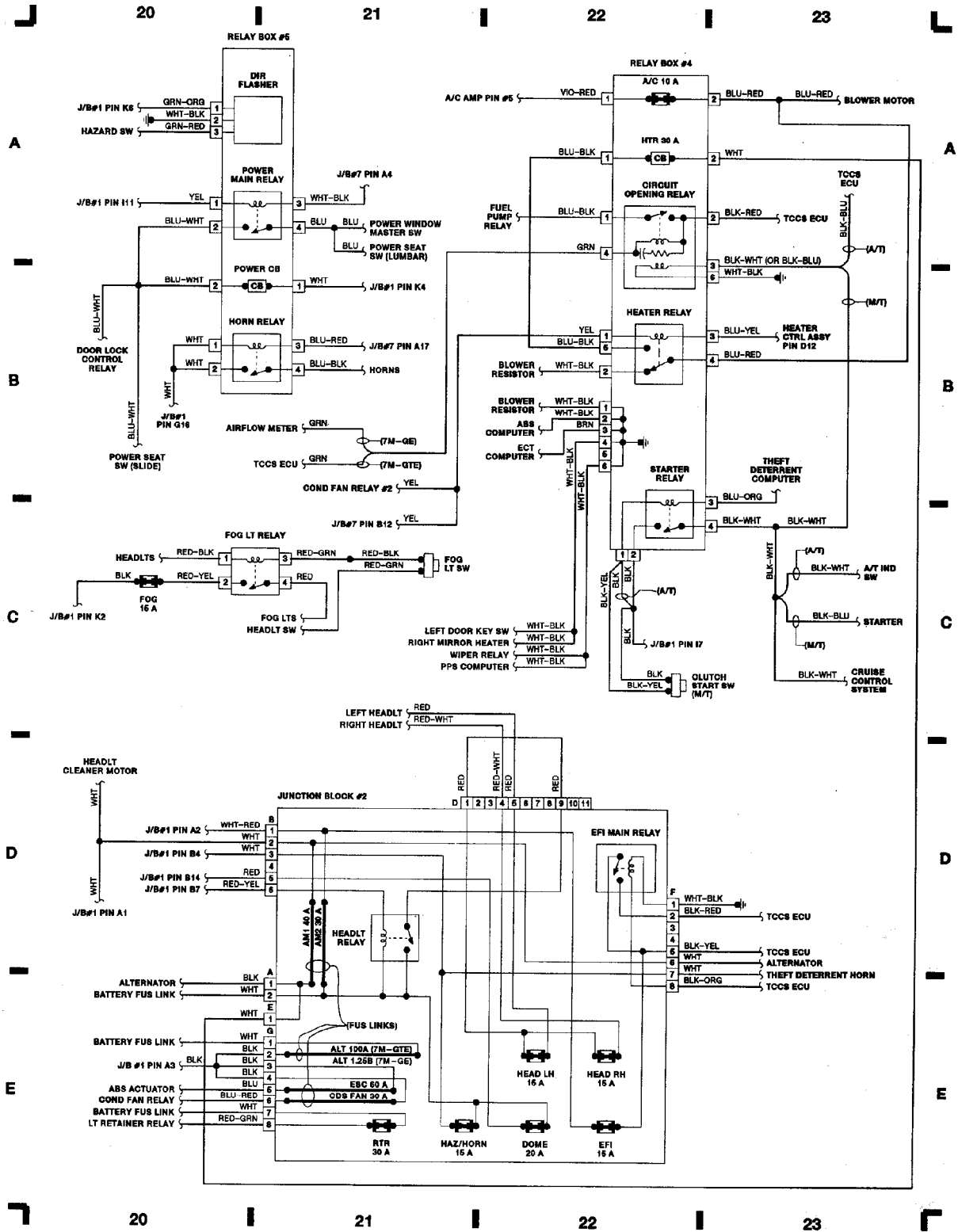

90C07366
Fig. 6: Relays & Headlight Control

WIRING DIAGRAMS
Article Text (p. 9)
 1989 Toyota Supra
 For www.jarwhite.ru
 Copyright © 1998 Mitchell Repair Information Company, LLC
 Tuesday, July 30, 2002 04:05PM

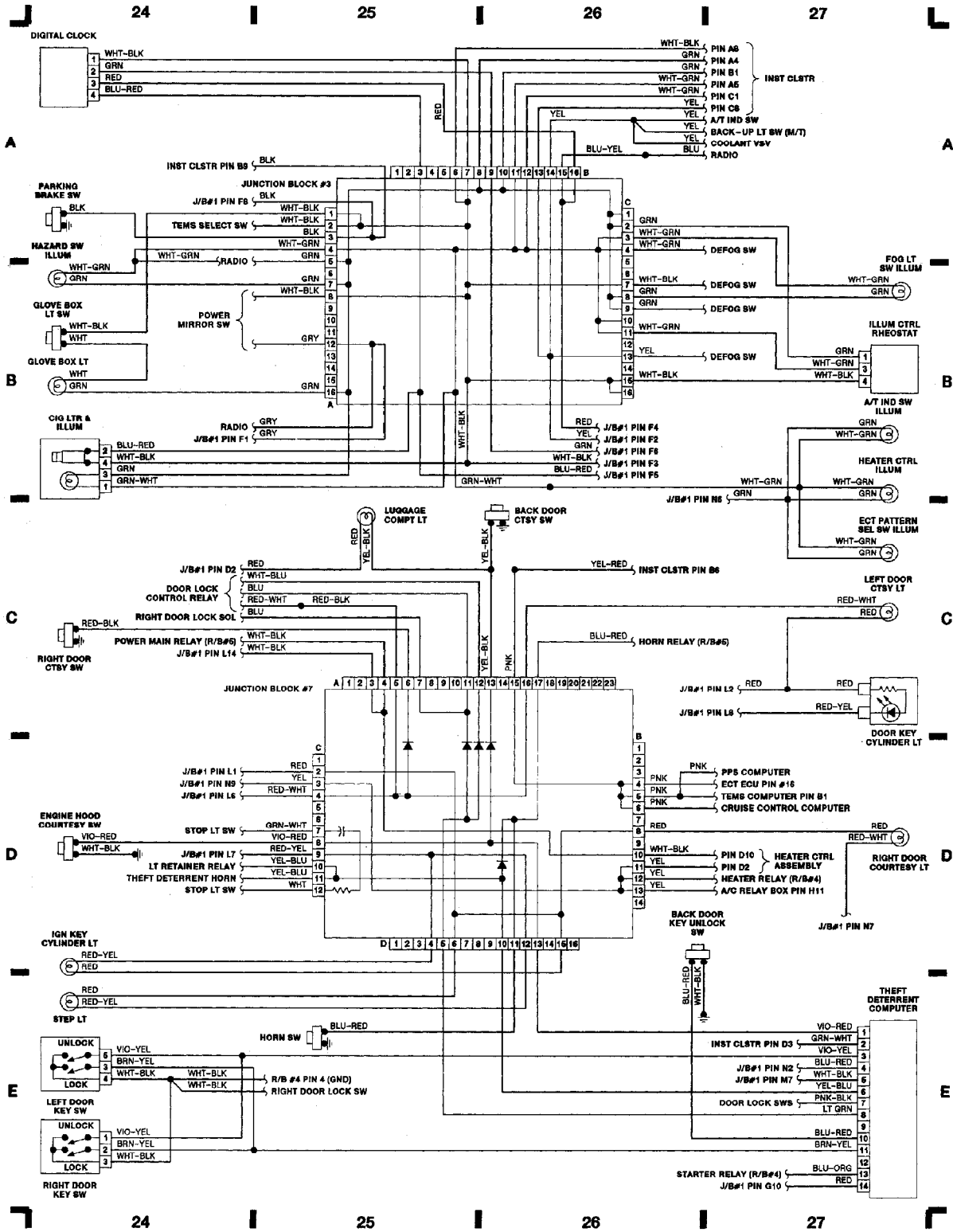

90E07367
 Fig. 7: Fuse Blocks No. 3 and No. 7

WIRING DIAGRAMS

Article Text (p. 10)

1989 Toyota Supra

For www.jarwhite.ru

Copyright © 1998 Mitchell Repair Information Company, LLC

Tuesday, July 30, 2002 04:05PM

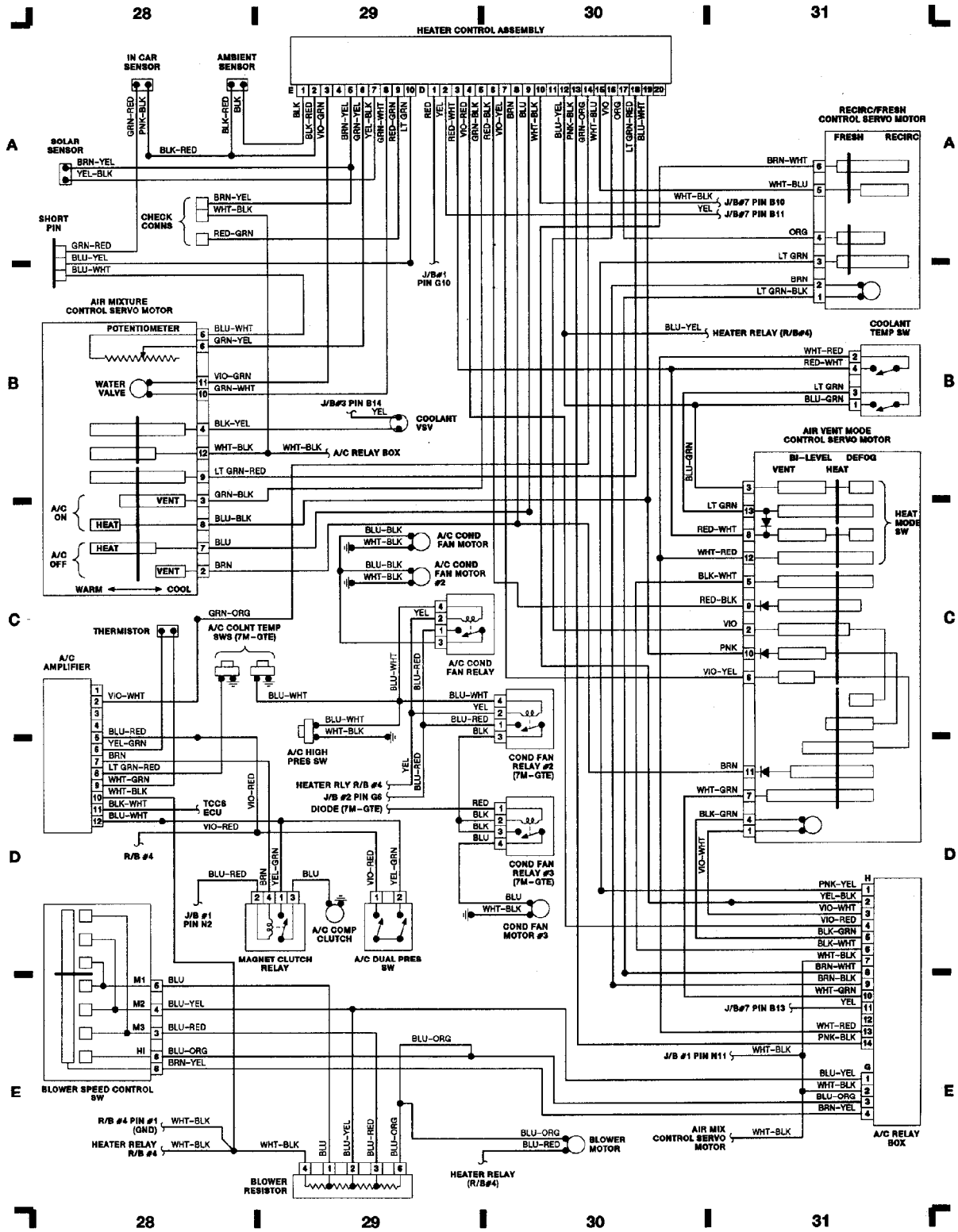

90G07368
Fig. 8: A/C & Heating

WIRING DIAGRAMS

Article Text (p. 11)

1989 Toyota Supra

For www.jarwhite.ru

Copyright © 1998 Mitchell Repair Information Company, LLC

Tuesday, July 30, 2002 04:05PM

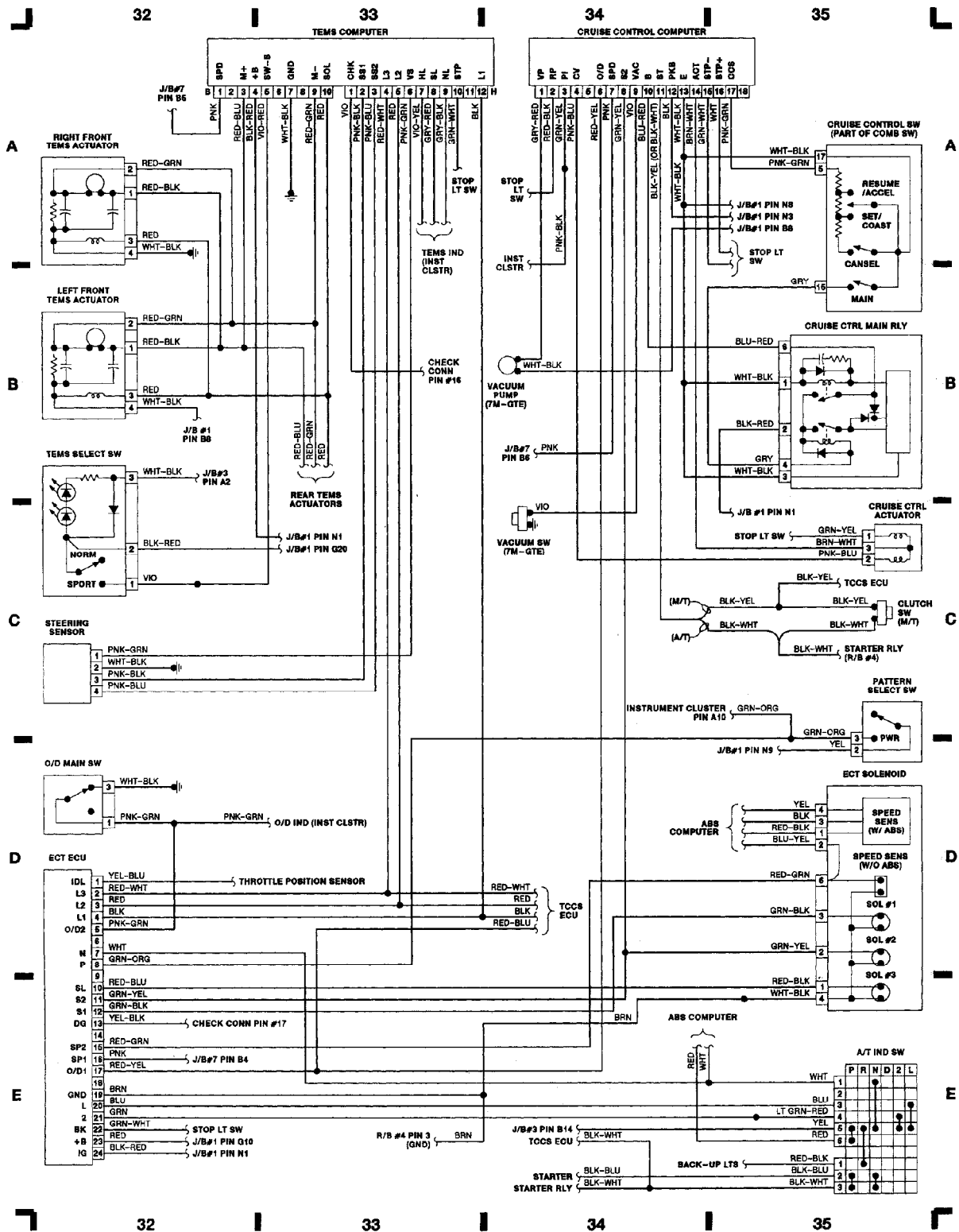

90107369

Fig. 9: Suspension Control, Automatic Transmission Control and Cruise Control

WIRING DIAGRAMS
Article Text (p. 12)
 1989 Toyota Supra
 For www.jarwhite.ru
 Copyright © 1998 Mitchell Repair Information Company, LLC
 Tuesday, July 30, 2002 04:05PM

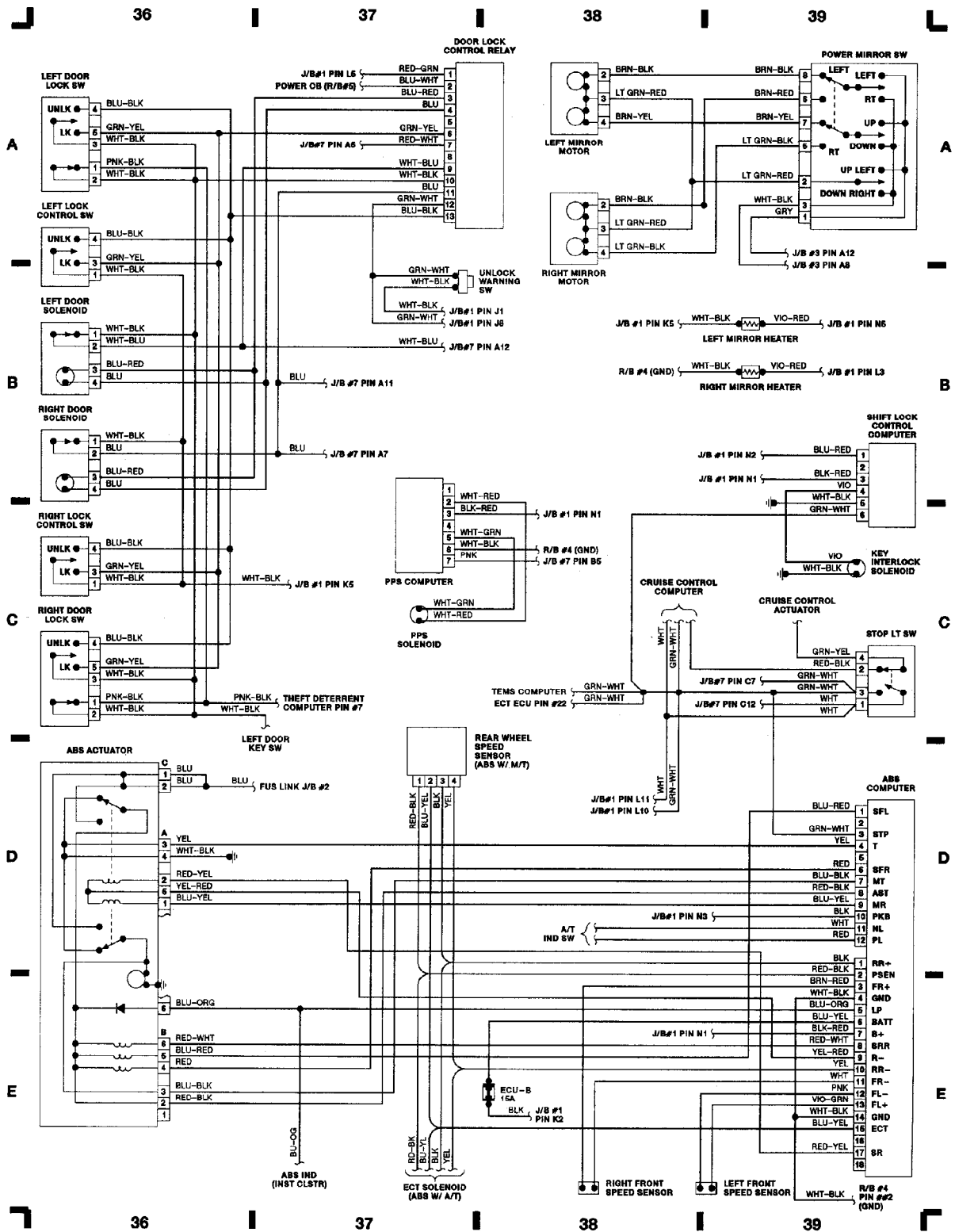

90A07370
 Fig. 10: Power Doors, Power Mirrors and Anti-Lock Brake System

WIRING DIAGRAMS

Article Text (p. 14)

1989 Toyota Supra

For www.jarwhite.ru

Copyright © 1998 Mitchell Repair Information Company, LLC

Tuesday, July 30, 2002 04:05PM

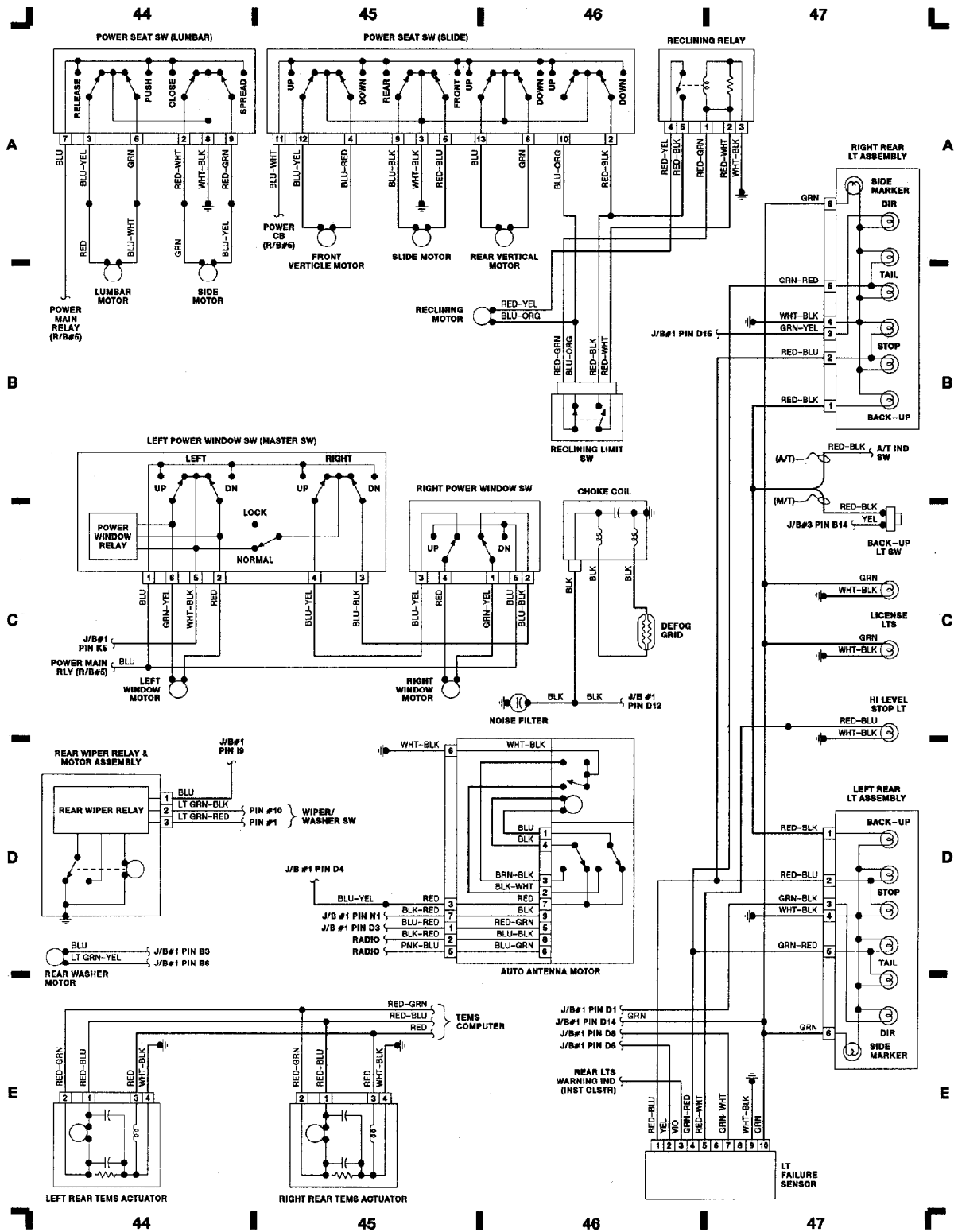

90E07372
Fig. 12: Passenger Compartment & Taillights

END OF ARTICLE