

# PhyzLab: Ørsted's Discovery

an investigation of the magnetic field around a current-carrying wire

PERIOD	1.		
	2.		
GROUP	3.		
	4.		

## • Discussion and Purpose •

What was the most important invention of the 19th century? History textbooks generally avoid science and technology in favor of politics. But they do make mention of the steam engine and the cotton gin. Both had significant impacts at the time of their development. But they live on only through museums and history textbooks. However, the electric motor—developed in the 1860's—is a device that now pervades everyday life. In this activity you will re-enact a perplexing discovery made by **Hans Christian Ørsted** (pronounced "UR-sted"), a Danish high school physics teacher, in 1820. You will see how the seemingly useless physics of this surprising discovery was engineered and refined into the electromagnet and the electric motor.

## PART A: ØRSTED IN 2D

### • Apparatus A •

- \_\_\_ high current battery (ignitor or 6V)
- \_\_\_ long wire
- \_\_\_ 2 compasses

*NOTE: There may be a steel spine on the bottom of your table. This spine can affect a compass needle, so keep compasses away from it. Stay away from the corners, too; there may be a steel plate where each steel leg is mounted to the table.*

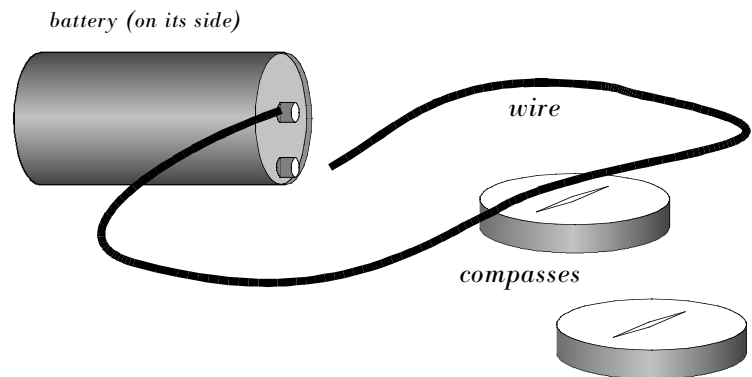

### • Procedure A •

#### 1. NO CURRENT

With the wire disconnected from the battery, use the compass to determine the magnetic characteristics of the copper wire (if any). The copper wire is coated with insulating plastic. The ends have steel alligator clips. Check the copper—not the steel—for magnetism. Record your observations using words and pictures. (For the pictures, add to the diagrams below.)

Compass pointing north

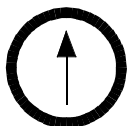

Does laying a wire from west to east across the compass change the direction it points?

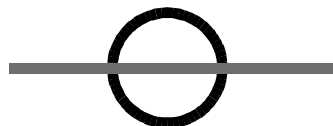

Does laying a wire from north to south across the compass change the direction it points?

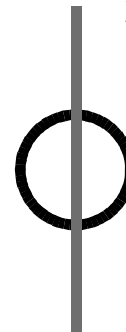

## 2. RUNNING CURRENT ACROSS THE TOP OF A COMPASS NEEDLE

What effect—if any—does a current-carrying wire have when placed **above** a compass needle? Answer using words and pictures. (To get current through the wire, simply connect both ends of the wire to the two terminals of the battery. CAUTION: This creates a short-circuit—don't keep it running more than 10 seconds at a time!)

The arrow on the wire to indicates the direction of current flow. Show the effect on the compass needle if there is one. (Always tap the compass a couple of times once the current is established in the wire.)

Compass pointing north

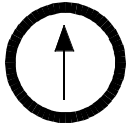

Does running current from west to east across the compass change the direction it points?

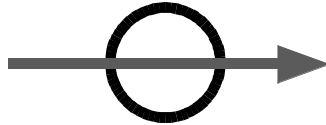

Does running current from north to south across the compass change the direction it points?

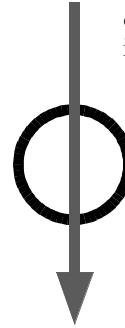

Does running current from east to west across the compass change the direction it points?

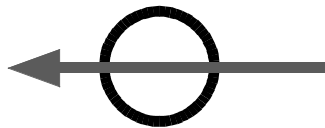

Does running current from south to north across the compass change the direction it points?

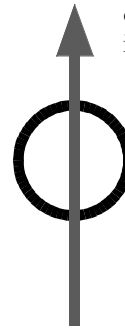

### 3. RUNNING CURRENT BENEATH A COMPASS NEEDLE

What effect—if any—does a current-carrying wire have when placed **beneath** a compass needle? Answer using words and pictures. (To get current through the wire, simply connect both ends of the wire to the two terminals of the battery. CAUTION: This creates a short-circuit—don't keep it running more than 10 seconds at a time!)

The arrow on the wire indicates the direction of current flow. Show the effect on the compass needle if there is one. (Always tap the compass a couple of times once the current is established in the wire.)

Compass pointing north

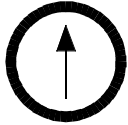

Does running current from west to east beneath the compass change the direction it points?

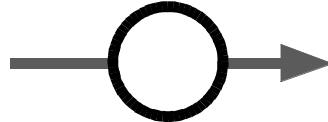

Does running current from north to south beneath the compass change the direction it points?

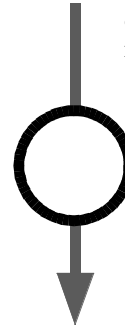

Does running current from east to west beneath the compass change the direction it points?

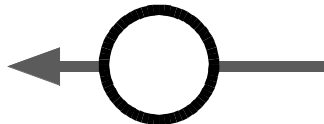

Does running current from south to north beneath the compass change the direction it points?

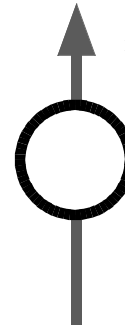

### PART B: ØRSTED IN 3D

In the previous part of the lab, you discovered that a compass needle is affected by a nearby electric current. But the deflection of the compass needle was somewhat peculiar. In this activity, you will complete the investigation of magnetism associated with electric current. By the end of this activity, you should have a clear idea of the shape of the magnetic field near a current-carrying wire.

#### • Apparatus B •

- \_\_\_ magnetic field near a current-carrying wire apparatus
- \_\_\_ several small compasses
- \_\_\_ DC voltage source (ignitor battery or power supply)
- \_\_\_ connecting wires

#### • Discussion B •

You are aware, from *Ørsted's Discovery*, that a magnetic field exists around a current carrying wire. (A compass needle is deflected when current passes nearby.) But what is the geometry of the field? *Ørsted's Discovery* did not provide a clear answer; the field above the wire was different from the field below the wire. In this activity, we place the wire vertically (instead of horizontally) and place compasses around it on a small platform. This allows us to "see" the field all the way around the wire (not just above and below).

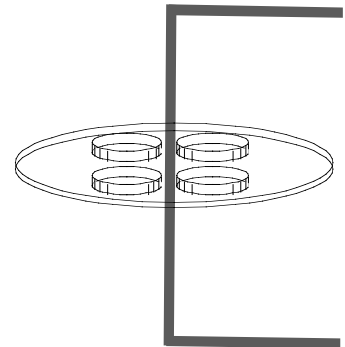

• **Procedure B** •

a. Arrange the apparatus as shown. Notice that one terminal of the battery is not connected (or notice the power supply is turned off). The compasses should be as close to each other as possible.

b. Look down on the compass platform from above. Sketch the compasses in the diagram to the right. (The compasses should all be pointing north; draw them as arrows pointing north. Disregard any directional markings printed on the compass.)

c. When the battery is connected, will current flow up through the wire (toward you) or down through the wire (away from you)?

d. Again draw the compasses on the compass platform, but do not draw the direction of the needles yet. Label the diagram in accordance with the direction of the current (TOWARD or AWAY). Show the direction of the current with an "arrow" at the center of the compass arrangement (where the wire passes through the platform). A "toward" arrow is drawn as a dot (•) with a circle around it; an "away" arrow is drawn as an  $\times$  with a circle around it.

e. Connect the battery (turn on the power supply). Tap the compass platform and allow the compasses to realign. Draw the directions of the compasses.

f. How could you describe the overall pattern you see in the compass needles? Which—if any—of the following words apply? Up, down, radial, tangential, left, right, in, out, clockwise, counterclockwise, horizontal, vertical.

g. Reverse the current by switching the leads on the magnetic field apparatus. **Do not change any other connections.**

h. Again draw the compasses on the compass platform, but do not draw the direction of the needles yet. Label the diagram in accordance with the direction of the current (TOWARD or AWAY). Show the direction of the current with an "arrow" at the center of the compass arrangement (where the wire passes through the platform). A "toward" arrow is drawn as a dot (•) with a circle around it; an "away" arrow is drawn as a cross ( $\times$ ) with a circle around it.

i. Connect the battery (turn on the power supply). Tap the compass platform and allow the compasses to realign. Draw the directions of the compasses.

j. How could you describe the overall pattern you see in the compass needles? Which—if any—of the following words apply? Up, down, radial, tangential, left, right, in, out, clockwise, counterclockwise, horizontal, vertical.

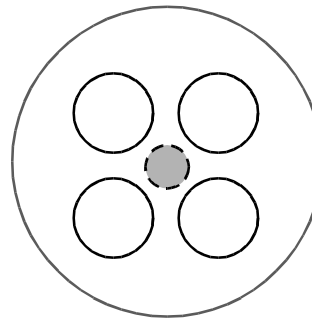
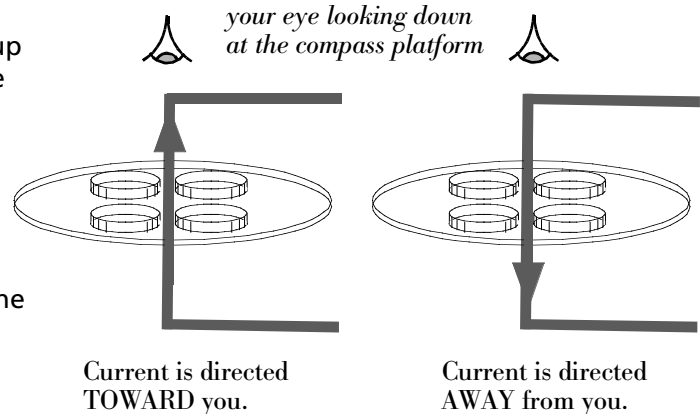
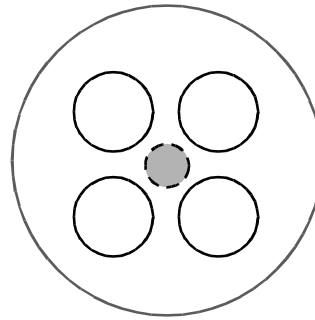

Draw the appropriate symbol indicating the direction of the current in the center circle (which represents the current-carrying pole).

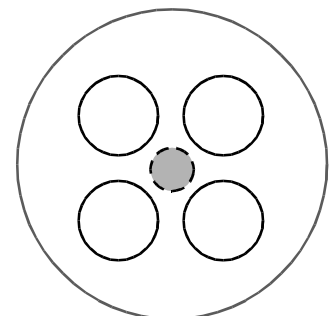

Draw the appropriate symbol indicating the direction of the current in the center circle (which represents the current-carrying pole).

• **Analysis B** •

1. The diagram to the right depicts a collection of compasses placed around a current-carrying wire. The direction of the current is indicated. Complete the diagram by drawing in the compass needles.

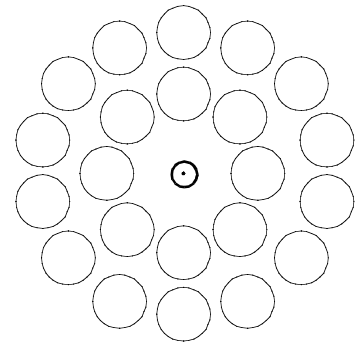

2. The diagram to the right depicts a collection of compasses placed around a current-carrying wire. The direction of the current is indicated. Complete the diagram by drawing in the compass needles.

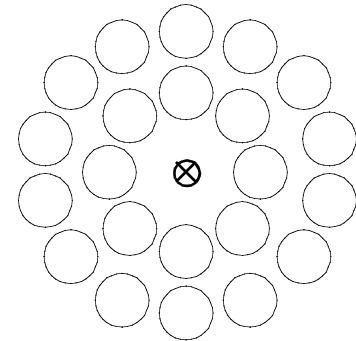

3. Which of the diagrams below correctly depicts the magnetic field surrounding a current-carrying wire? (Circle it.)

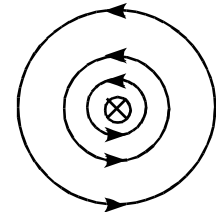
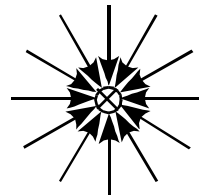
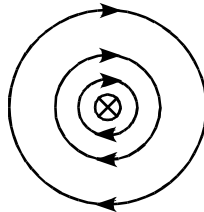
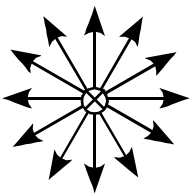

4. RIGHT HAND RULE FOR MAGNETIC FIELDS

a. With your right hand, imagine grabbing a current-carrying wire with your thumb pointing in the direction of current flow. Now allow your fingers to wrap around the wire. Which way do they point relative to the magnetic field surrounding the current-carrying wire?

b. Indicate the direction of the magnetic field around the current-carrying wires at each point indicated below. The direction of the current is shown by the arrow on the wire.

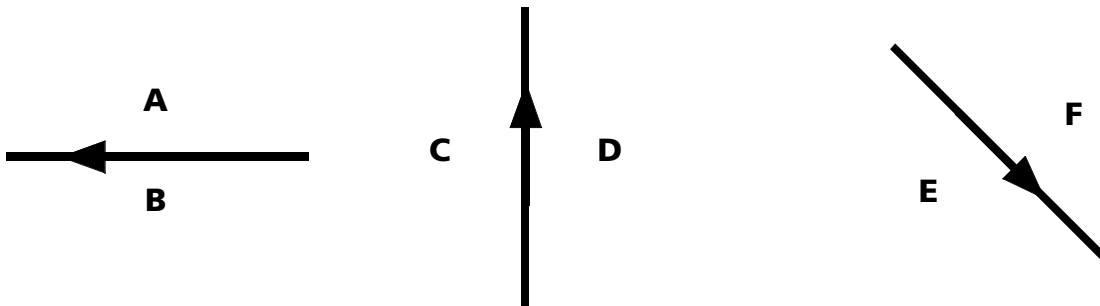

#### 4. RIGHT HAND RULE FOR MAGNETIC FIELDS

c. Indicate the direction of the current carried in the wire in each case below. The direction of the magnetic field near the wire is shown.

