

**Platonic Solids
Geodomes
...and other structures
of the mind.**

**"Incredibly unique
student/teacher
workshops about
math and structures."**

**Mallory Bagwell
25 LedgeWood Drive
Farmington, CT 06032
(860) 673-1758 vox
(520) 438-6453 fax
mallory.bagwell@home.com**

Platonic Structures

In this series of hands on workshops, participants:

- **Become exposed** to the five Platonic solids and their inherent characteristics that make them useful as building tools.
- **Construct their own geo-structures**, spans, towers, bridges, and domes while exploring the physics and aesthetics behind form and function.
- **Erect a two story tall dome** to understand the concept of frequency, the strength of triangles in geodesic structures, and how to calculate chord lengths.
- **Examine and evaluate suitable materials** (pvc pipe, coffee stirrers, rolled newspapers, pipe cleaners, cardboard....) for strength, sway, compression, stability, and longevity when used for domes, towers, spans, bridges, and polyhedra.
- **Learn Unit Origami** and use it to create a Tetrahedron, Hexahedron, Octahedron, Dodecahedron, & Icosahedron.
- **Understand the Vocabulary** and taxonomy of naming polyhedral shapes and to identify, construct, or solve for:

Regular Solids	Perimeter
Semi-Regular	Solids Area
Frequency	Volume
Truncated Group	Vertices
Cubocta Group	Edges
Icosadodeca Group	Faces

- **Are provided with suitable carryover materials** for continuation and replication of the workshop concepts and activities.
- **Draw connections** between the art of mime, architecture, geometry, and writing as real life "structurings" of the mind. The formation of ideas, and their subsequent notation, depiction in space, organized and structures are all central to the realization that symbols are used to create structures of ideas in space.
- **Realize** that "art" and "academic" content areas contain languages that serve to choreograph structures of the mind onto space.

Preparatory Materials

- **Definitions**
- **Taxonomy**
- **History**
- **Polyhedra Cut-outs**

History

A polyhedron can be described as a set of polygons enclosing a portion of three-dimensional space. Polygons are two-dimensional figures. The prefix "poly" means "many" and the suffixes "hedron" and "gon" mean faces and angles respectively. These, and all other words used in naming geometric shapes, come from the Greek language. It was the ancient Greeks who first made an extensive study of geometry.

Polygons form the **FACES** of a polyhedron. These polygons are situated so that every side of each one shares a side with another polygon. These shared sides are the **EDGES** of a polyhedron. When two or more edges of a polyhedron meet they form a **VERTICE** (point) of the polyhedron.

A polygon is called **REGULAR** if all its sides are the same length and all its angles are equal.

A polyhedron is **REGULAR** if all its faces are the same and its vertices are alike.

A polyhedron can be called **SEMI-REGULAR** if its faces contain more than one type of regular polygon and all its vertices are uniformly surrounded by these polygons.

THERE ARE ONLY FIVE REGULAR POLYHEDRA

The simplest polyhedra are the five known as the regular solids. They are also called the **Platonic bodies, or solids**, after the ancient Greek philosopher Plato (380 B.C.) who showed a special interest in them. In the article, *Regular Polytopes*, a Professor Coxeter explains;

"The early history of these polyhedra is lost in the shadows of antiquity. To ask who first constructed them is almost as futile as to ask 'Who first used fire?' The tetrahedron, hexahedron, and octahedron occur in nature's crystals of various substance; sodium sulphantimoniate, common salt, and chrome alum respectively). The two more complicated regular solids cannot form crystals but need the spark of life for their natural occurrence. Haeckel observed them as skeletons of microscopic sea animals called radiolaria....All five were treated mathematically by Theaetetus of Athens in Books XIII-XV of Euclid's elements.

Euclid is, of course, very heavy reading for students of today. Modern geometry books have certainly simplified the presentation of polyhedra, but no amount of reading can take the place of making models to examine first hand. It should be noted that a sphere is not a regular solid yet each of the five regular solids, when placed in a sphere, will have each of its vertices touching the surface of the sphere.



THIRTEEN SEMI-REGULAR POLYHEDRA

Archimedes (250 B.C.) is one of the ancient Greeks who showed a deep interest in the polyhedral shapes. He wrote a treatise on the thirteen semi-regular solids. Although his original work has not come down into modern times, the thirteen semi-regular solids are also called the Archimedean solids in his honor.

The ancient Greeks developed proofs as to why there are only five regular solids and thirteen semi-regular solids. Simply stated the possibilities for regular polyhedra are limited by the condition that all the faces be regular polygons. Furthermore, the arrangement of faces around each vertex must be made so that the sum of the face angles equals 360 degrees. The thirteen semi-regular polyhedra are closely related to the regular group. These thirteen shapes can be arranged in three sub groups called the:

TRUNCATED GROUP

This group is created by taking each of the regular polyhedrons and cutting off the vertices in such a way as to produce a regular polygon face. The names are:

1. Truncated Tetrahedron
2. Truncated Hexahedron
3. Truncated Octahedron
4. Truncated Dodecahedron
5. Truncated Icosahedron

CUBOCTA GROUP (Octahedral Symmetry)

6. Cuboctahedron
7. Rhombi-cuboctahedron
8. Rhombi-truncated-cuboctahedron
9. Snub-cuboctahedron (or snub cube)

ICOSIDODECA GROUP (Icosahedral Symmetry)

10. Icosidodecahedron
11. Rhombi-icosidodecahedron
12. Rhombi-truncated-icosidodecahedron
13. Snub-icosidodecahedron (or snub dodecahedron)

Definitions

Poly = many
Gon = angle
Hedron = faces

Geo = earth
Dome = house

Compression = pushing force
Tension = pulling force

Poly + gon = Many angles. A two dimensional figure that enclose a space.

Poly + hedron = Many faces. A set of polygons enclosing a 3-dimensional space.

Polygons form the faces of polyhedra.

Polygons and polyhedrons can be regular (Platonic) or semi-regular (Archimedean). There are 5 regular and 13 semi-regular.

A regular polygon is a polygon with equal sides and equal angles.

A regular polyhedron is a polyhedron with equal faces and equal vertices.

A semi-regular polygon has unequal sides and unequal angles.

A semi-regular polyhedron is made with more than one one kind of regular polygon and vertices uniformly surrounding it.

Point = A single dot in space. No width, length, or height.

Line = Formed by two points in space. Has length only.

Plane = Formed by two intersecting lines. Has width and length.

Solid = Formed by two intersecting planes. Has **width, length, and height**.

Polygons have three parts. A vertice, an edge, and a face.

Vertice = The points of a polyhedron or solid. E.g. tip of a pyramid.

Edge = The lines of polyhedra or solids. Where planes or faces meet.

Face = The planes or flat surfaces of a polyhedron.

One dimensional = Theoretically ontaining only the dimension of width.

Two dimensional = Containing only length and width. E.g., polygons.

Three dimensional = Containing length, width, and height. E.g., polyhedra.

Taxonomy

Prefixes

Tetra	= four
Penta	= five
Hexa	= six
Octa	= eight
Deca	= ten
Dodeca	= twelve
Icosa	= twenty

To name a REGULAR polyhedron, count the faces, find the Greek prefix which corresponds to that number, and add the word gon on the end of the prefix.

A pyramid has 4 equal triangular faces. Four = tetra. Tetra + gon = Tetragon.

Can you figure out the correct name for a cube?

Naming the semi-regular solids can be tricky. Herewith a few guidelines. To name a semi-regular solid or a compound solid, read the section on history of polyhedra.

- Truncated** = Each vertice of a regular polyhedron has been cut off in such a way to produce a face formed from a regular polygon.
- Rhombi** = Means square and indicates the presence of square faces on polyhedra.
- Compound** = A symmetrical arrangement of two or more given solids. They may be the same kind of solid or different kinds. The relationship of these solids may be interlocking or interpenetrating whereby they share some of their interior spaces.
- Stellation** = A compound formation process applied to a polyhedron whose facial planes are extended in space until they enclose more space outside the given solid.
- Rotation** = A compound formation process whereby a solid is rotated about a point or axis and the subsequent positions are imposed upon the original starting position.
- Frequency** = Refers to the number of planes required to form each triangle of a geodome. The sections of a dome larger than an icosahedron can not form a dome unless each of the triangles bends. The larger the dome, the more bends each triangular section must make to create closure. The number of planes in each section is the frequency of that particular dome.
- Duals** = Each regular solid has a dual whereby either solid of a dual pair can be enclosed in the other with vertices of one touching the center points of the faces of the other. A tetrahedron is a dual of itself.

Tetrahedron

Four triangles

Four vertices

Dual: Itself

Surface Area = $4 \left(\frac{1}{2} \text{Side} \cdot \text{Height} \right) = 2SH$

Volume = $\left(\frac{1}{3} \right) (H) (S)^2$

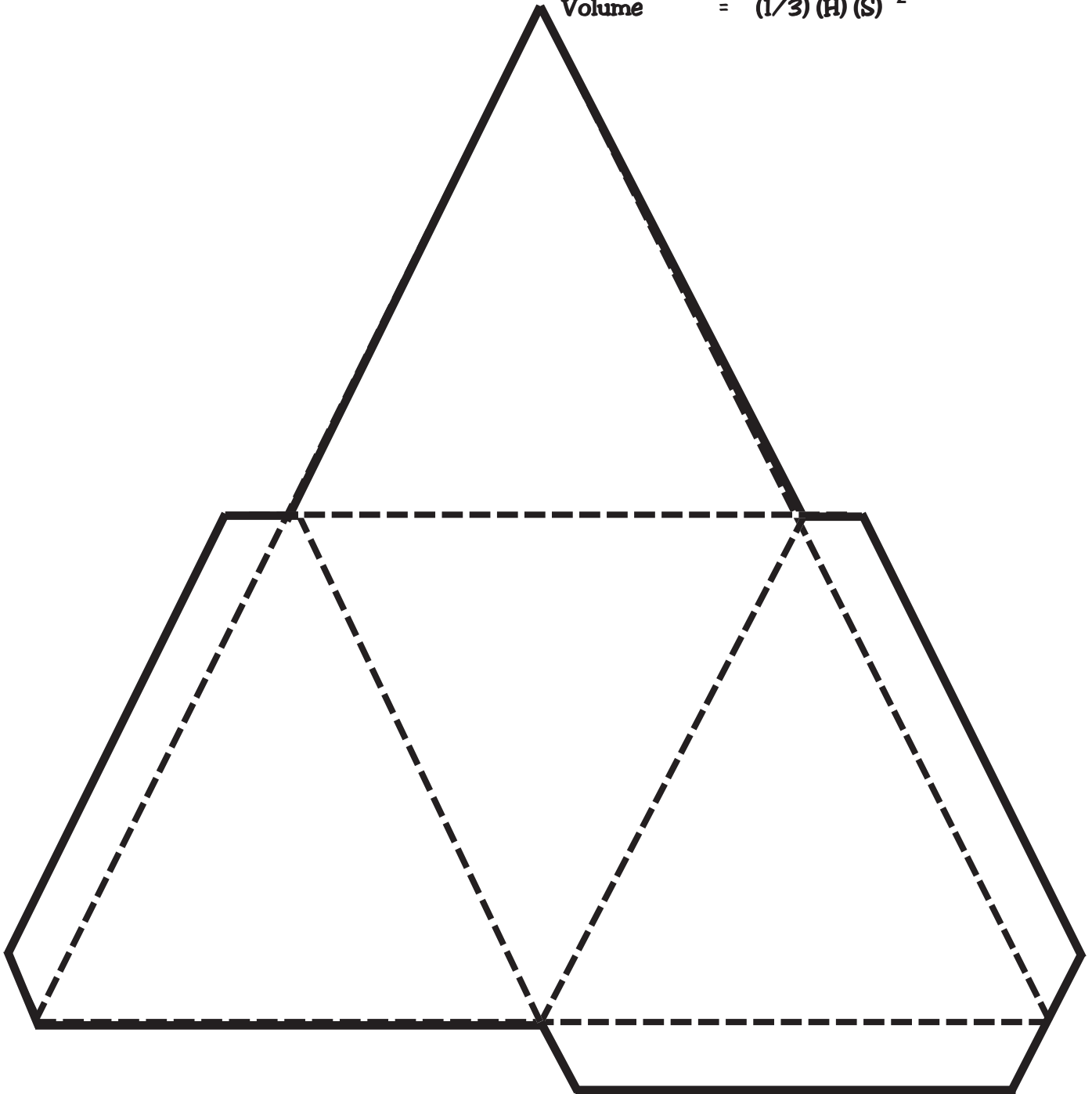

Hexahedron

Six squares

Eight vertices

Dual: Octahedron

Surface Area = $6S^2 = 6 \text{ (Side} \cdot \text{Side)}$

Volume = S^3

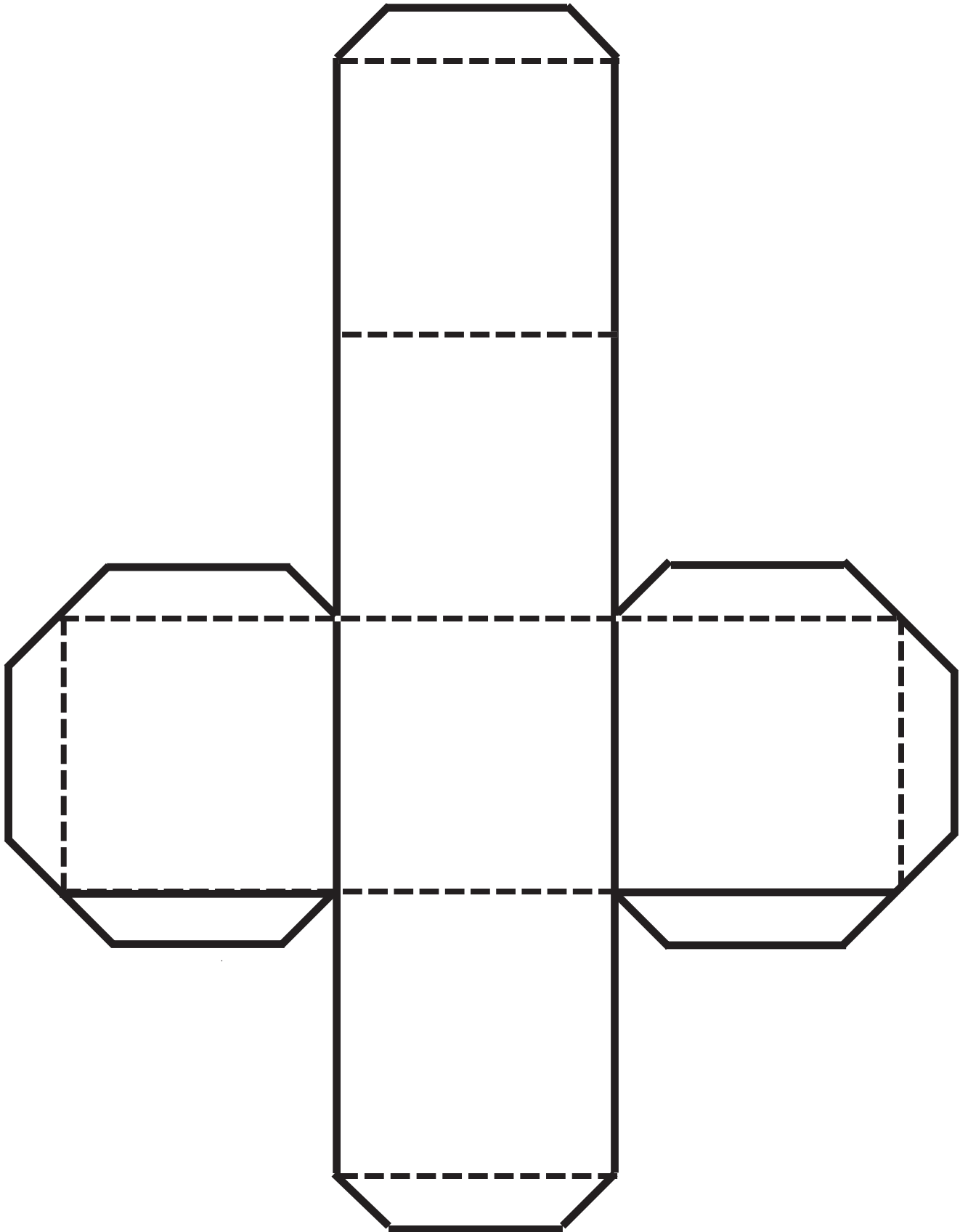

Octahedron

Eight triangles

Six vertices

Dual: Hexahedron

Surface Area = $4SH = 4 \cdot \text{Side} \cdot \text{Height}$

Volume = $\frac{2}{3} HS^2$

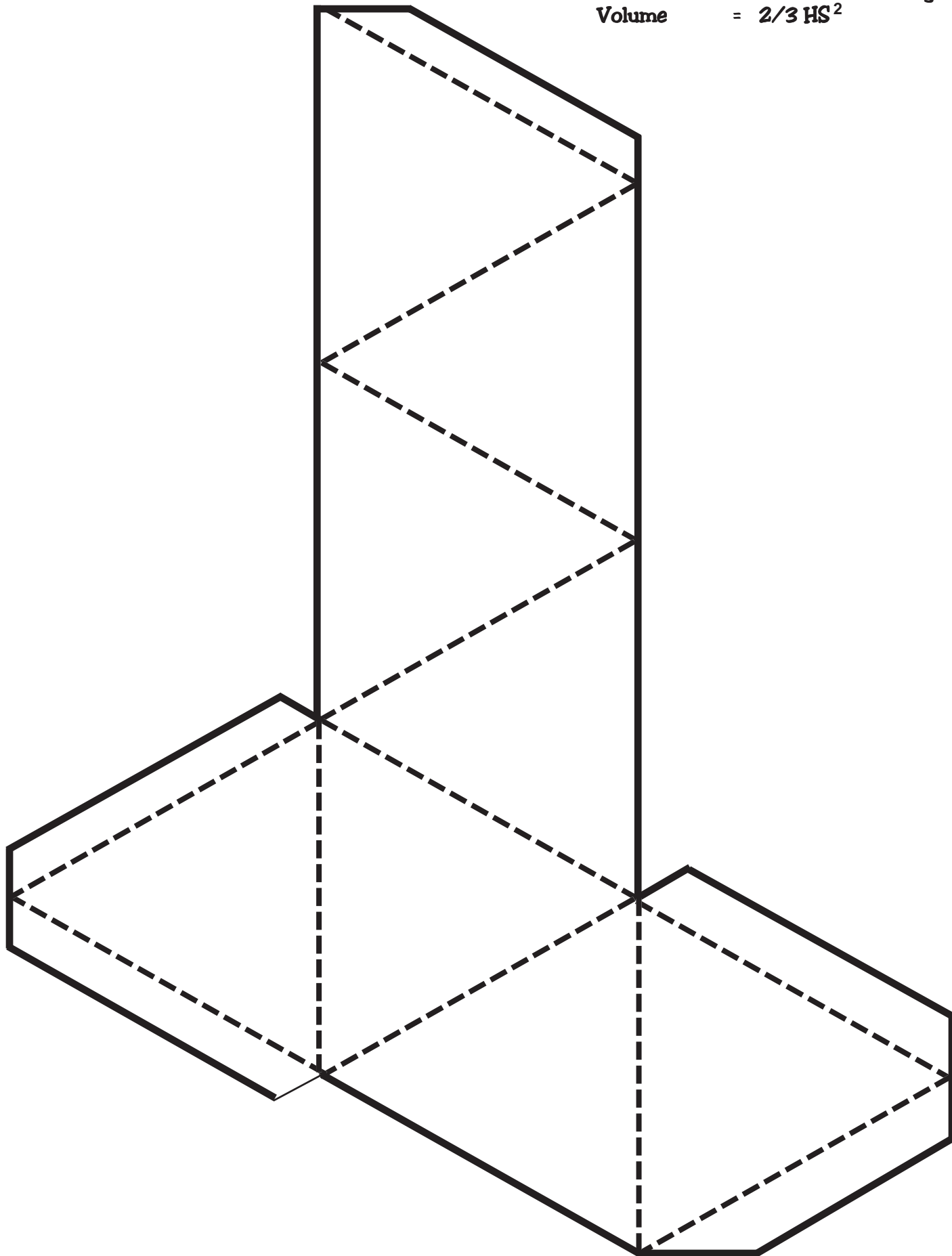

Dodecahedron

Twelve pentagons

Twenty vertices

Dual: Icosahedron

Surface Area =

Volume =

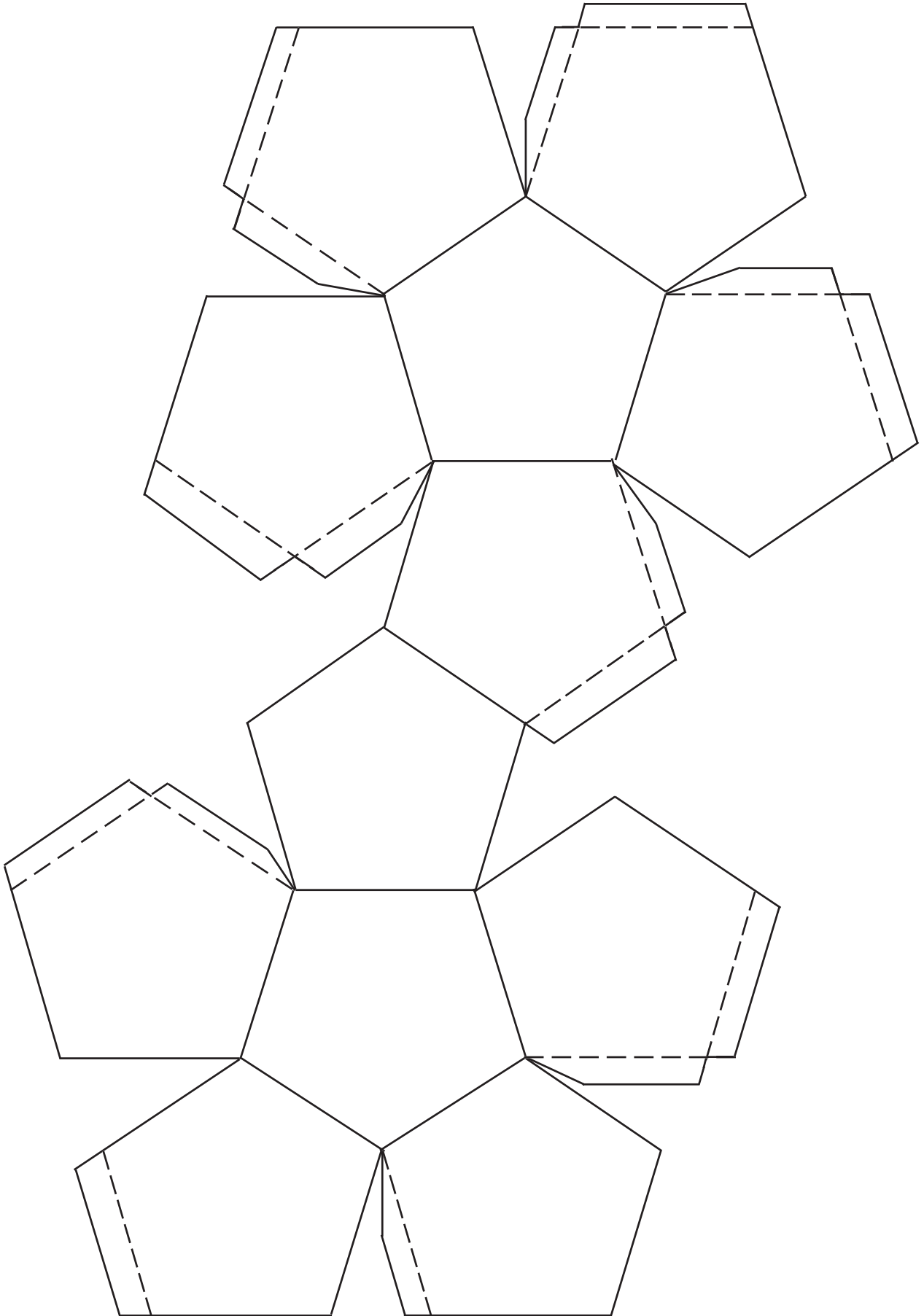

Icosahedron

Twenty triangles

Twelve vertices

Dual: Dodecahedron

Surface Area = $20 \left(\frac{1}{2} \text{Side} \cdot \text{slant height} \right)$

Volume = $\frac{1}{3} \text{Surface Area} \cdot \text{height}$

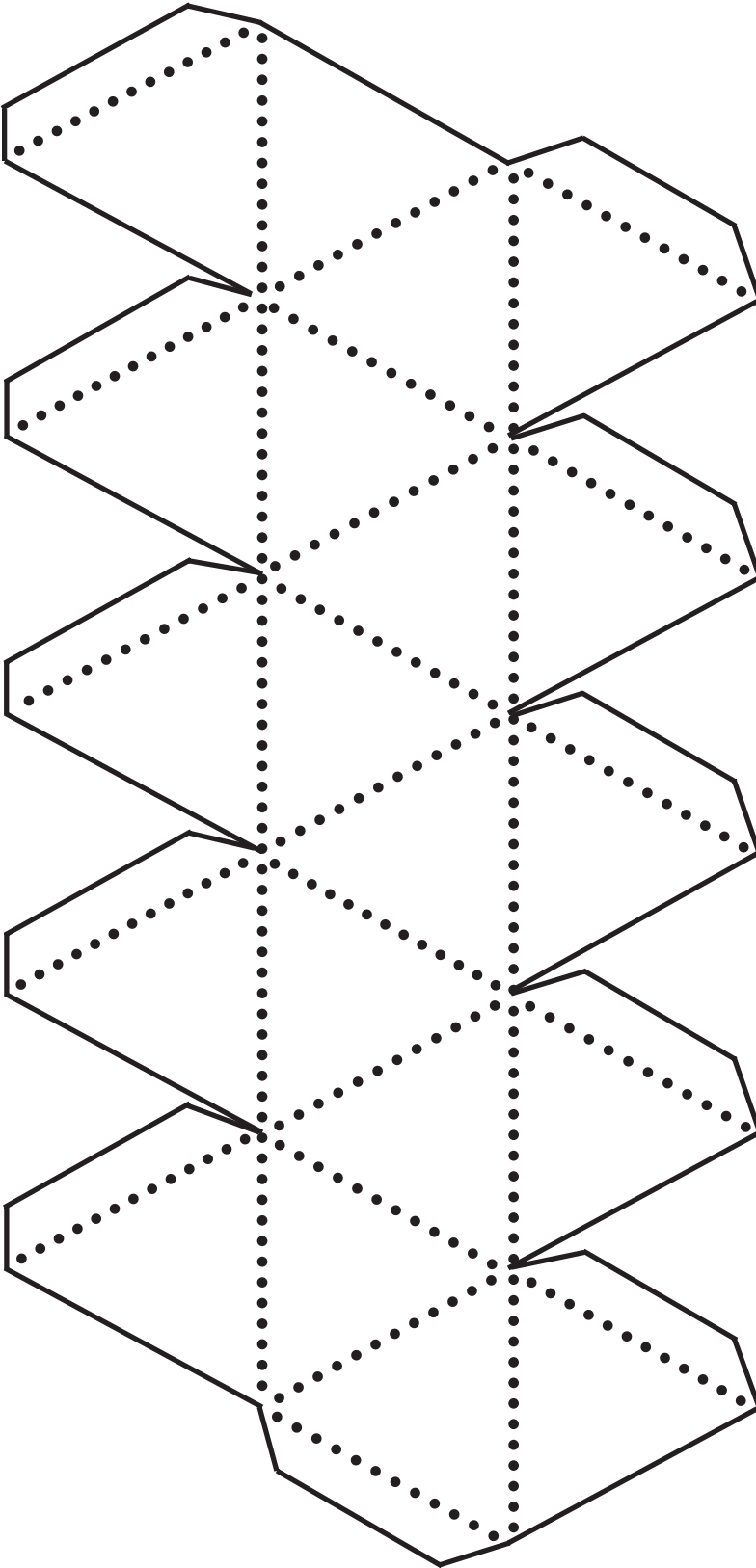





Characteristics

Polyhedron	Edges	Vertices	Faces		
1					
2					
3					
4					
5					

Composition

Platonic Solids
(or regular solids)

Archimedean Solids
(or irregular solids)

No.	Polyhedrons	Shape & No. of Faces					Faces	Edges	Vertices
									
1.	Tetrahedron	x 4					4	4	6
2.	Hexahedron		x 6				6	8	12
3.	Octahedron	x 8					8	6	12
4.	Dodecahedron			x 12			12	20	30
5.	Icosahedron	x 20					20	12	30
6.	Truncated Tetrahedron	x 4			x 4		8	12	18
7.	Truncated Hexahedron	x 8				x 6	14	24	36
8.	Truncated Octahedron		x 6		x 8		14	24	36
9.	Truncated Dodecahedron	x 20				x 12	32	60	90
10.	Truncated Icosahedron			x 12	x 20		32	60	90
11.	Cuboctahedron	x 8	x 6				14	12	24
12.	Icosidodecahedron	x 20		x 12			32	30	60
13.	Rhombicuboctahedron	x 8	x 18				26	24	48
14.	Rhombitruncated Cuboctahedron		x 12		x 8	x 6	26	48	72
15.	Rhombi-Icosidodecahedron	x 20	x 30	x 12			62	60	120
16.	Rhombitruncated Icosidodecahedron		x 30		x 20	x 12	62	120	180
17.	Snub Cube	x 32	x 6				38	24	60
18.	Snub Dodecahedron	x 80		x 12			92	60	150

Area & Volume

