

# **THE FRUGAL TELESCOPE MAKER:**

Telescope Making for those Short on Money and Mechanical Aptitude

Rico Tyler  
Version 6.6  
Oct.. 2001

## Introduction

It is almost impossible to think about astronomy without envisioning telescopes. They are as much a symbol of the discipline as a hammer is to carpentry or a gradebook is to teaching. But this fascination has a price. Even a small telescope can have large price tag. Yet telescopes are not especially complicated devices. This reasoning has led many to try making their own telescopes. A great deal of skill, thought and craftsmanship go into these creations. The results often surpass the quality of commercial telescopes. But one look at these telescopes is enough to convince most people that telescope making is beyond the skills and tools of the average stargazer. But making a small telescope need not tax ones skill, toolbox or budget.

This booklet will show how to put together an excellent small telescope without having a fully equipped woodshop and metalworking facilities. Instead of a concave mirror these telescopes use lenses, some of them surplus, available by mail order. This makes the telescopes refractors instead of the reflectors often made by amateurs. Refractors are rugged, require little if any upkeep and are easy to setup and transport. The mechanical parts and mountings will be made from assorted pieces of hardware and plastic pipe. Only common hand tools are needed (of course power tools are always welcome). The results can rival equipment costing hundreds of dollars.

This booklet has plans for two different telescopes. One is a 61.7 mm diameter refractor with a focal length of 700 mm. The second design is identical except for having a focal length of 415 mm. Both of these telescopes can be used on any of three mounts. The first is a rugged 4 ft. tall "pier" mounting. The second is a portable "bucketscope" mount. The third is a compact version of the "pier" called the "short pier" mount

## HOW A TELESCOPE WORKS

Anyone who has shopped for a telescope in a department store knows that magnification is the great selling point of some telescope makers. But telescopes are designed to accomplish three goals, the *least* important being magnification. In fact the "power" of a telescope comes from it's eyepiece. By changing eyepieces an observer can get a wide range of magnifications from almost any telescope. The real test of a telescope is how well it shows detail, known as *resolution*, and how much light it collects.

### Objective Lens

The key to resolution and light gathering ability is the objective lens. This is the large lens in the front of a refracting telescope or pair of binoculars. It's purpose is to collect light from whatever it is aimed at and focus that light to form an image. While this image is small it is much brighter than an image made by your eye. This is because the objective has a diameter or *aperture* much greater than the eye. This allows a telescope to collect more light than can enter your eye.

Aperture also gives a telescope it's resolution. This explains why a telescope is referred to by the diameter of the objective. Telescopes are usually compared by aperture. When an astronomer speaks about a "80 millimeter" refractor or a "6 inch " telescope she is speaking about aperture. Both telescopes illustrated in this booklet have an aperture of 61.7 mm.

### Eyepieces

The eyepiece ,or *ocular*, is simply a magnifier. In fact an ordinary pocket magnifier can do a creditable job as an eyepiece. While magnifiers usually magnify real objects, in a telescope they magnify the image made by the objective. Magnifying brings out the detail in an image. Different eyepieces increase or decrease magnification.

While it is possible to magnify the image in the smallest telescope by huge factors the more an image is magnified the dimmer the image gets. Making the image twice as large makes it four times dimmer. Magnifying the image also magnifies the effects of air turbulence, the shaking of the mount and any slight flaws in the objective. Telescope users try to magnify an image only as much as needed to bring out all the detail in an image.

### Operation of a Telescope

A completed telescope pairs an objective and an eyepiece. The tube merely holds the pieces in

place. The tube needs to be long enough so that the eyepiece is just behind the location of the image made by the objective. For distant objects the image is at the objectives focal point. As you try to focus on nearby objects the eyepiece will need to be pulled further away. The position of the eyepiece also needs adjusting when switching from one eyepiece to another. For this reason most telescopes have some means to adjust or focus the eyepiece.

The magnification of a telescope is found by dividing the focal length of the objective by the focal length of the eyepiece.  $Magnification=f(\text{objective})/f(\text{eyepiece})$ . It is easy to see that the objective needs a long focal length while the eyepiece needs a short focal length. The telescopes in this booklet have a focal length of 700 or 415 mm.

## **Objectives and Eyepieces**

### Objectives

The objectives for both of the telescope plans come from:

**Sky Instruments  
MPO Box 3164  
Vancouver B.C. Canada V6B 3Y6  
604-270-2813  
1-800-648-4188**

Call Glen Speers at Sky Instruments for current prices. Depending on which telescope you wish to make you will be ordering a 61.7 mm diameter commercial grade objective with a focal length of 415 or 700 mm. The cost per objective varies from \$24.00 to \$17.10 depending on quantity.

### Eyepieces

The telescopes described here work best with eyepieces having focal lengths between 12 and 24 mm. The longer focal lengths give better field of view and image brightness while the short focal lengths provide higher magnifications.

The simplest way to acquire eyepieces is to purchase them commercially. Both designs in this booklet accept any standard 1.25 in eyepiece. Sky Instruments offers Kellner eyepieces for \$26.00 or less depending on the order size. Magazines such as *Astronomy* or *Sky and Telescope* have ads from many other manufacturers and dealers. Major manufacturers include Celestron, Orion, Meade, Televue and others. Prices will range from about \$30.00 to nearly \$100.00 Any 1.25 in eyepiece will work well. Focal lengths between 10 mm and 25 mm are best.

### Making Your Own Eyepiece

Making your own eyepieces is easy and much less expensive. Surplus microfilm or small projection lenses, available by mail order from several surplus dealers, can be turned into usable eyepieces. Look for one with a suitable focal length for an eyepiece and having a diameter of no more than about 25 mm. The cost is ranges between 5 to 8 dollars. Since surplus parts go in and out of stock constantly it is hard to give specific examples to order. Finding the right lens is a matter of hunting through catalogs. If you do not find what you want in a catalog be sure to call the dealers. They often have surplus optics not mentioned in their catalogs. I have had good experiences with two surplus companies.

**American Science and Surplus  
3605 Howard St.  
Squeak, Illinois 60076  
847-982-0870  
Fax 800-934-0722  
and**

**C and H Sales Inc.  
P.O. Box 5356**

Pasadena CA. 91117-9988

1-800-325-9465

Fax 818-796-4875

Even better eyepieces can be made from binocular eyepieces, microscope objectives and other mounted lens sets available from both Sky Instruments and Paul Rini. Their prices are very competitive and the end product is usually much better than ordinary surplus microfilm lens. Call them for product availability and pricing.

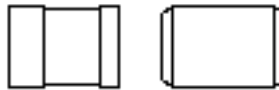

Fig. 1: Typical microfilm and projection lenses

### Part List: Homemade Eyepiece

- 1- Eyepiece Lens
- 1- 3/4 in. Pull Through "Tee" (A plastic fitting used with electrical conduit)
- 1-"First Surface" mirror ( can be ordered from most science supply catalogs or American Science and Surplus as order number 2726 three pack for \$2.75- enough for 6 telescopes. A second American Science mirror is order number 4112)
- Epoxy Glue and Electrical Tape
- Black marker
- 35 mm Film Container

Begin by cutting the bottom out of a gray 35 mm film container. These containers have the same 1.25 in diameter as regular astronomical eyepieces. Epoxy the container by its top to one side of the "tee". After the epoxy sets tightly wrap the joint with a single turn of electrical tape.

Next remove the "tees" backplate and use a marker to blacken the interior. This will stop any internal reflections. Then use a glass cutter to cut a piece of first surface mirror large enough to cover the open back. Be sure to use a first surface mirror. Regular mirrors, which have their aluminum coating on the back of the glass, will cause ghost images and blurring. Use the backplate and screws to attach the first surface mirror to the "tee". Be sure the "first" mirrored surface faces the interior.

The last step is to wrap a few turns of electrical tape around the eyepiece and friction fit it into the "tees" second opening. The eyepiece should have a snug fit that that does not allow the lens to actually touch the mirror. The finished eyepiece can now be inserted into a telescope.

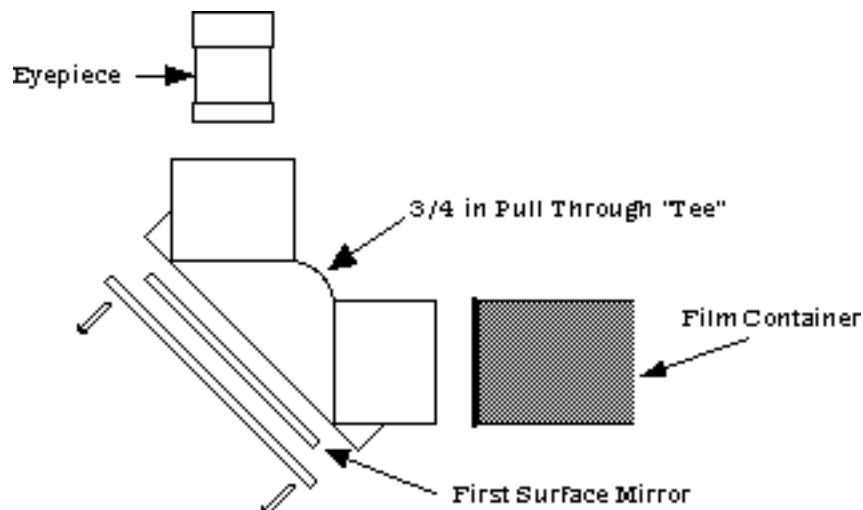

Fig. 2: Making a Diagonal

A variation of this design will work with 1.25 in eyepieces. Instead of a 3/4 in pull through "Tee" use a 1 in. PVC Schedule 40 "Tee". Cut the "Tee" at a 45 degree angle .

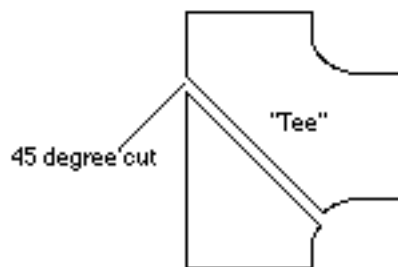

Fig. 3: Cutting a PVC "Tee"

Attach a first surface mirror and open bottomed film container as in the previous design. The Film Container will actually slide into the "Tee" for a short distance. Make sure to insert the container before gluing.

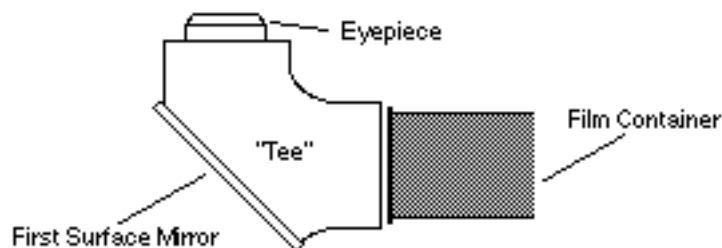

Fig. 4: View of PVC "Tee"

Finish the "Tee"by adding a few shims of adhesive felt around the eyepiece side of the "Tee" to hold the eyepiece by friction

### Telescope Designs

PVC pipe is the key to building a simple telescope. This hardware store staple is cheap, easy to cut, durable and comes in different diameters. A wide range of fixtures is also available. All PVC parts and fittings used here are schedule 40 PVC. Be sure to ask for it by name.

#### PVC Telescope-700 mm version

This is an ideal telescope for those wanting good views of the Moon, Jupiter and Saturn. It uses the Sky Instruments 61.7 mm diameter/700 mm focal length objective mentioned in the section on objectives.

#### Parts List: 61.7 mm dia. 700 mm FI Telescope

- 1-21 in. section of 2 in. PVC ( body)
- 1-2 in. section of 2 in. PVC ( dew cap)
- 1-8 to 10 in. section of 1.5 in. PVC ( focuser)
- 1- 1.5 in. to 1.25 in reducer (commonly known as a female compression fitting)
- 2- 1/4 in carriage bolts (1.5 in long) with washer and wingnut for each
- 1- piece of 3/4 in PVC pipe ( about 14 in long)
- Black Electrical Tape
- Flat Black Spray Paint
- 1- Piece of self adhesive Felt
- 1- 9 in by 2 in piece of thin cardboard or plastic stock (card stock or thinner-soda bottle plastic works great)

Construction of this telescope begins with painting the interior of both the 2 in PVC pipe and the 1.5 in pipe with black spray paint. After the paint has dried a pair of 1/4 in holes should be drilled through the middle of the 2 in pipe. These holes will be used to mount the telescope.

Each hole must have a carriage bolt inserted from the inside of the pipe. The pipe is too narrow to do this by hand. The 3/4 in pipe can be notched at one end to make a "widget" that allows carriage bolts to be inserted from the inside out.



Fig. 5: A "Widget"

Once each bolt is placed it should have a washer and carriage bolt attached and screwed in tight. This tightening allows the bolt to dig into the inner wall of the pipe. Afterwards the wingnuts can be loosened. Be sure to never remove the wingnuts as that will allow the bolts to fall out.



Fig. 6: Telescope Tube after Carriage Bolts Have been Placed

The next step is to attach the objective lens to the telescope tube.

**WARNING!!!**

Special care must be taken with the objective lens. It is airspaced and unmounted. In common terms this means the two elements, convex and concave, are not attached. They are separated by a thin plastic ring. Be careful not to lose the ring or drop either lens of the pair. A loose set such as this needs a special method of mounting.

Take one end of the pipe and carefully wrap electrical tape around one lip to make a bushing with the same outside diameter as the objective. The bushing should be flush with the lip of the PVC. Make a similar bushing for the dew cap.

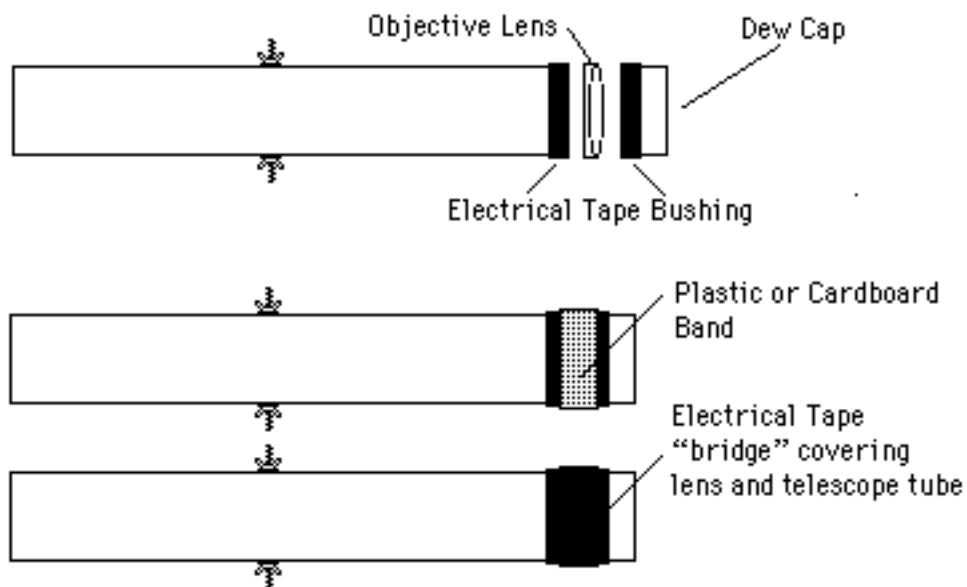

Fig. 7: Mounting the objective

Assemble the telescope tube, objective and dew cap as one unit (make sure the objectives convex element is facing the dewcap). Then tightly wrap a 9 in piece of thin cardboard or plastic around the entire tube-objective-dewcap assembly and hold it in place with a piece of tape. This "band" will kept the objective from shifting relative to the telescope tube. The last step is to tightly wrap electrical tape around the entire assembly. The tape will securely hold the objective to the telescope and the dew cap to the objective. Stretching the tape will help it adhere better. A single thickness wrap of tape is enough.

Next place the trap adapter securely on the piece of 1.5 in pipe. If the fitting feels loose you can glue it with PVC cement. The eyepiece will fit into the compression fitting. The 1.5 in. pipe will be placed into

the rear of the telescope and used as a focuser. Unfortunately the 1.5 in pipe is too thin for a good fit. A sheet of felt with an adhesive back is used to get the proper fit.

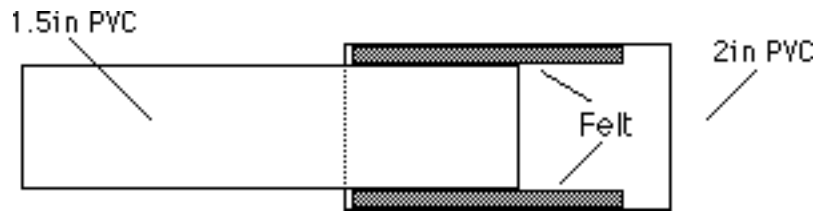

Fig. 8: Giving the Drawtube a Good Fit

Once the objective is installed cut the adhesive felt into strips about 1 in. wide and 3 to 4 in long. Use these strips to line the end of the 2 in PVC pipe. The felt may need to be two layers deep in places before it will securely hold the focuser. The grip should be firm but allow the telescope to be focused.

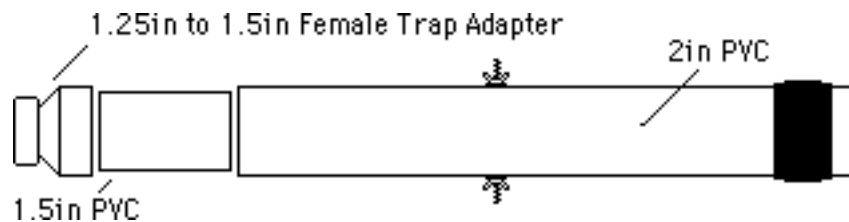

Fig. 9: Exploded View of the PVC Telescope

The 1.5 in pipe acts as a drawtube to focus the telescope. The telescope should focus with no more than about one half of the drawtube exposed.

#### PVC Telescope-415 mm version

While the 700 mm PVC telescope offers excellent performance and is very portable and compact it is over two ft long. An even more portable telescope can be made using a 415 mm. focal length lens instead of a 700 mm. objective. This compact version can store inside of all three different mounts. It is constructed in exactly the same manner as its longer brother using resized parts.

#### Parts List: 61.7 mm dia. 415 mm FI Telescope

- 1-10 in. section of 2 in. PVC ( body)
- 1-2 in. section of 2 in. PVC ( dew cap)
- 1-5 in. section of 1.5 in. PVC ( focuser)
- 1- 1.5 in. to 1.25 in reducer (commonly known as a female compression fitting)
- 2- 1/4 in carriage bolts (1.5 in long) with washer and wingnut for each
- 1- piece of 3/4 in PVC pipe ( about 14 in long)
- Black Electrical Tape
- Black Spray Paint
- 1- Piece of self adhesive Felt
- 1- 9 in by 2 in piece of thin cardboard or plastic stock (card stock or thinner)

Assembly of this telescope is exactly the same as its longer sibling. This short telescope will yield less magnification with a given eyepiece than the 700 mm. telescope but will have a larger field of view and is very stable. It is a good choice for looking at comets and deep space objects such as nebulae and galaxies.

#### Construction Note

Both versions of the telescope work best with a diagonal. The diagonal is the piece that turns the eyepiece 90 degrees. Without a diagonal the drawtube must be pulled further back to achieve proper focus. If you plan to use your telescope without a diagonal I suggest increasing the length of the overall

telescope by 1 to 3 in.

## Telescope mountings

Both telescope designs need a mount for the telescope tube. All three mountings included in this booklet need a "cradle to hold the telescope. This cradle is called a fork arm. It is made from 1 by 2 in wood and four dry wall screws. One way to get the proper width wood is to cut a piece of 1 in. by 10 in. wood into four strips. Wood wider than 2 in. is acceptable.

Cut two identical side pieces for the fork arms (Fig. 9). Each side piece should have notches to hold the telescope. I usually cut fork arms 6 in long. They can be cut longer if desired.

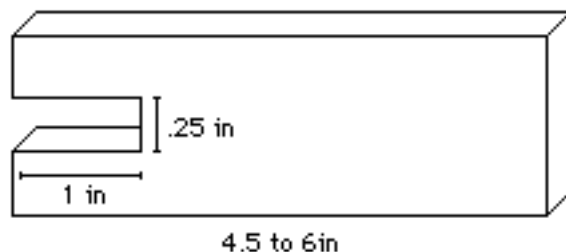

Fig. 10: Fork Arm Side Pieces

The base of the fork is a third block as long as your telescope tube is wide plus an extra 1.5 in to handle the sides to the fork. This usually works out to be 3 7/8 in. This allows the telescope to fit snugly between the arms. **BE SURE TO CHECK THIS MEASUREMENT!** The piece should also have a 1/4 in. hole drilled through the center. This will allow the fork to be attached to a mount. The pieces are then glued together and allowed to dry. Afterwards drill 4 small pilot holes for drywall screws ( 1.5 to 2 in work very well) as illustrated (Fig. 10).

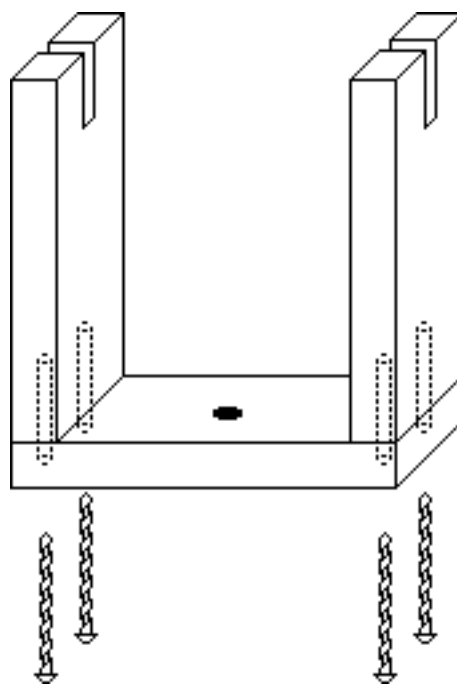

Fig. 11: Assembling the fork

These holes should have a slightly smaller diameter than the screws being used to prevent the wood from splitting. If dry wall screws are unavailable finishing nails make a good substitute. Be sure to use very small diameter pilot holes for nails!

The space between the arms should be just wide enough for the width of the telescope tube. Be sure to double check all measurements to ensure a snug fit. The completed fork can be used with any mount in this booklet.

The pier mount, short pier and the bucket mount are all topped by caps having a 1/4 in. hole. A 1/4 in carriage bolt inserted up through this hole provides a mounting point. The fork is attached to the bolt and held in place by a wingnut and washer ( Fig. 11). The space between the fork arm and the cap has a

second washer to allow the fork to turn freely without any wobbles. This washer is made from a 35 mm film container with a hole cut in its center. Once the carriage bolt and wingnut are in place tighten the entire assembly. For an even stronger mount use 1/2 in carriage bolts instead of 1/4 in.

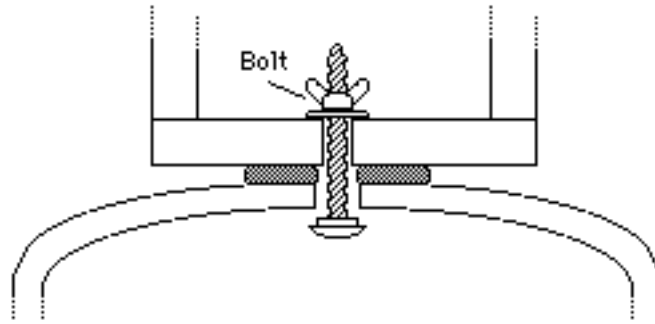

Fig. 12: Fork mount carriage bolt base

## MOUNTINGS FOR TELESCOPES

### Bucket Mount

The bucket mount is a simple and very portable mounting. It will work with both telescopes type described in this booklet but is really meant for the 415 mm telescope. All parts of the mount store inside the bucket ( including the telescope if you are using the 415 mm version).

#### Parts List: Bucket Mount

- 1-5 gallon "pickle bucket"
- 1-10 in. piece of 1.5 in. PVC
- 1-10 in. section of 2 in. PVC
- 1-11 in. section of 3 in. PVC
- 1-1.5 in. PVC cap
- 1-2 in. to 1.5 in. PVC reducer
- 1-3 in. to 2 in. PVC reducer
- 1- PVC Closet Flange
- 4- 1/4 in. carriage bolts with washers and wingnuts for each
- PVC cement

The first step in making a bucket mount is, of course, to find a bucket. This should be a 5 gallon heavy gauge bucket with a lid. They are commonly used to store pickles, icing and other food stuffs. Similar buckets are used for drywall compound, floor wax and other bulk products. While any of these will do the best buckets are those that have lids lacking any kind of spout.

Aside from some 1/4 in carriage bolts the rest of the mounting is made from PVC pipe and fittings. The diagram (Fig. 12) shows the needed parts and how they fit together.

Each piece of pipe is topped by a fitting glued with PVC cement. This makes three sections that in turn are held together by friction. The closet flange is attached to the bucket top by 4 carriage bolts. This will require cutting or drilling 4 holes in the bucket lid. The wingnuts and washers should be on the lid's bottom side. To store the mount simply pull each section apart. They will then store inside each other and can be placed into the bucket.

Telescopes are attached to the mount with the fork arm described earlier. The 1.5 in cap at the top of the mount should have a 1/4 in. hole for attaching the fork mount (see Fig. 11).

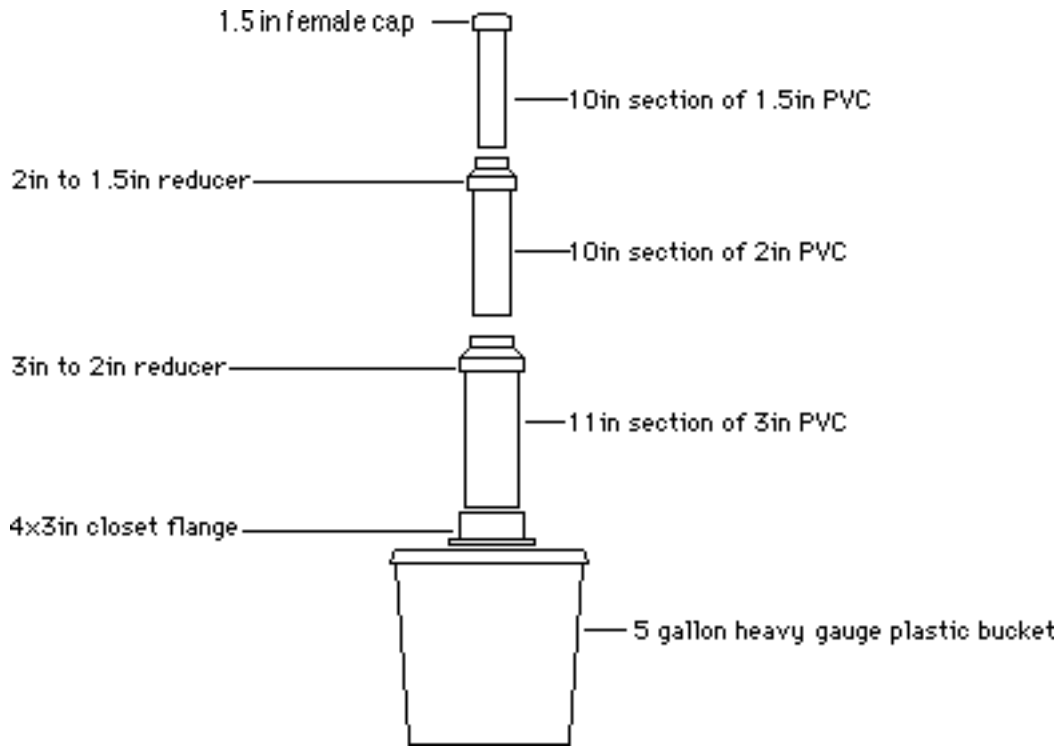

Fig. 13: Bucket Mount plans and parts

#### Pier Mount

The pier mount is a general purpose mount for both the 700 mm and 415 mm telescopes. It is rigid and has the proper height for standing use. One feature of the pier mount is a storage space for the telescope built into the pier itself.

#### Parts List: Pier Mount

- 1- 40 in (3.3 ft) section of 4 in PVC Pipe
- 1- 4 in Cap
- 3- 2 in Carriage Bolts with wingnuts and washers
- 3- 18 in long pieces of wood ( 3 in. wide lengths cut from a 1 by 10 in. board work best)
- 3- small blocks of wood
- 6- 3 in Mending Plates
- Finishing Nails
- Large foam rubber ball or piece of foam rubber

The three 18 in wood pieces make pier legs. The legs are arranged as seen in the figure below. Use the 4 in PVC pier as a form to maintain proper placement (Fig. 13). Each leg is joined to its partners by mending plates. The legs must fit snug against the pier. When all the legs are attached insert the 4 in pipe flush with the bottom of the leg assembly. Then drill three holes through both the legs and the PVC. Carriage bolts inserted through each hole attach the legs to the pier. These carriage bolts can be removed to separate the legs for storage. Finish the legs with small blocks of wood used as "feet". Glue and nails are used to attach a "foot" to the bottom of each leg.

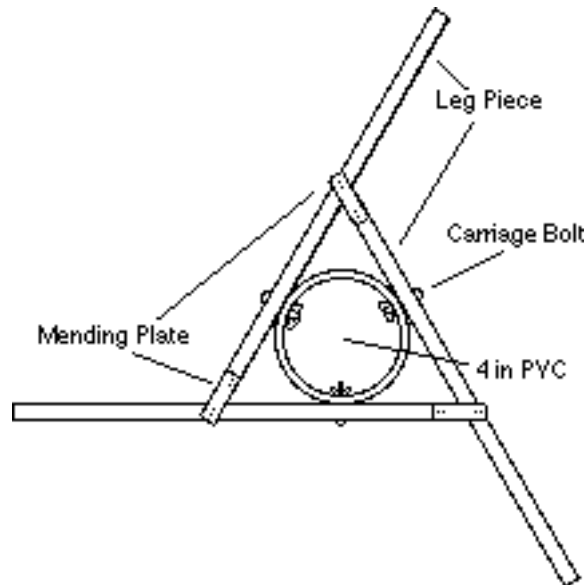

Fig. 14: Pier legs as seen from below

A 4 in. cap is the pier's top. The cap should have a 1/4 in. hole drilled in its top. A 1/4 in. carriage bolt is pushed up into the cap. The fork arm is attached to this and kept in place with a wing nut (see Fig. 12). When the top is completed a large piece of foam rubber is forced down the 4 in PVC. A telescope can be placed inside of the pier for storage by lifting off the 4 in. cap. The foam rubber will keep the telescope from falling through the pier and will also cushion the telescope.

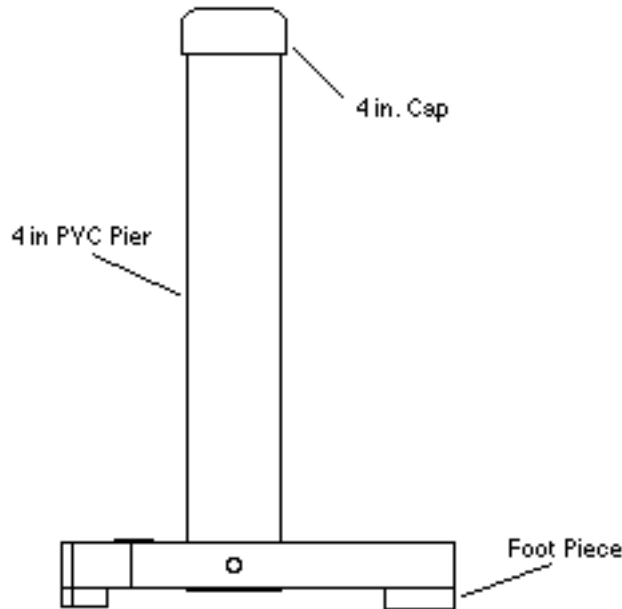

Fig. 15: Completed Pier Mount

### Short Pier Mount

The short pier mount is a smaller and more portable variation on the regular pier mount. It is also an extremely easy mount to assemble. It can be used with both 700 mm and 415 mm telescopes. The 415 mm telescope can be stored within the pier.

### Parts List: Pier Mount

- 1- 2 ft section of 4 in PVC Pipe
- 1- 4 in Cap
- 1- 4x3 in Closet Flange

Large foam rubber ball or piece of foam rubber

The only difference between the pier and short pier is the leg system. Instead of wooden legs the short pier uses a closet flange as the base. Because of the 2 ft height the short pier needs a table top or other surface to be at viewing height.

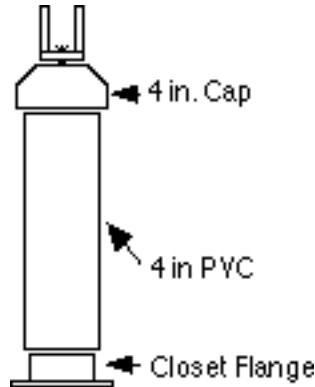

Fig 16: Exploded View of Short Pier Mount

## CONCLUSION

Hopefully this booklet will get you started in "bare bones" telescope making. A little willingness to experiment can produce wonderful results. If you find an interesting lens, design a new mount or telescope, need some help or just have some comments please feel free to call or write.

Rico Tyler

Practitioner in Residence  
Western Kentucky University  
Dept, Of Middle Grades and Secondary Education/ Physics and Astronomy  
1 Big Red Way  
Bowling Green Ky. 42101

270-745-6199 (w)

270-586-9518 (H)

Rico.Tyler@wku.edu

rtyler@aol.com

I look forward to hearing from you.

## NOTICE TO USERS

This booklet is intended for teachers and others interested in astronomy education. I give Permission to duplicate this booklet for nonprofit educational uses by classroom teachers and others doing teacher professional training or public outreach. All copies should be complete and include all information about the author. Give notice to the author of your use of this booklet.

## OTHER USEFUL STUFF

A current copy of these plans is available on the internet at:

**<http://members.aol.com/bemusabord>**

A special thanks go to Tom Bemus for hosting the plans on his site. If you are interested in more information on making your own eyepieces try: